

THE MAGAZINE FOR CONSUMER ELECTRONICS SERVICING PROFESSIONALS

ELECTRONICTM

Servicing & Technology

AUGUST 1989/\$2.50

A New-Technology Survival Guide

Servicing Zenith Microcomputers — Part II

Replacement Parts Showcase



AN INTERTEC PUBLICATION

www.americanradiohistory.com

Cut Your Video Troubleshooting Time By 54%* With The VA62A Universal NTSC Video Analyzing System

**New
And Improved!**



**VA62A Universal Video Analyzer
Patented**

- Identify tuner problems with All-Channel, VHF, UHF, and Cable RF Generators.
- Pinpoint IF Problems with modulated troubleshooting signal and exclusive programmable IF/RF generators.
- Isolate any video problems with patented video and standard color-bar patterns.
- Find defective stages, without disconnecting parts, using exclusive phase-locked drive signals.
- Test yokes and flybacks, plus measure signal levels with autoranged digital meter.

* Based on a nationwide survey of users who reported an average time savings of 54% compared to their previous test equipment.

Call 1-800-SENCORE
(736-2673)
In Canada 1-800-851-8866

Update For New Technology With Exclusive Phase-Locked Accessories

VC63 VCR Test Accessory

Solve the VCR servicing challenge with substitute VCR signals, phase-locked to your VA62A.



NT64 NTSC Pattern Generator

Meet all Warranty Requirements by adding the NTSC full-field and split-field patterns to your VA62A Universal Video Analyzer.



ST65 Video Analyzer Stereo TV Adder

Easily test and troubleshoot today's new MTS Stereo TVs & VCRs.



RG67 NTSC Video Monitor Adaptor

Expand into analog and digital video monitor service with phase-locked R, G, B and I signals.



SENCORE

Circle (1) on Reply Card

EXPAND YOUR CAREER HORIZONS...



The CIE Microprocessor Trainer helps you to learn how circuits with microprocessors function in computers.

START WITH CIE.

Microprocessor Technology. Satellite Communications. Robotics. Wherever you want to go in electronics... start first with CIE.

Why CIE? Because we're the leader in teaching electronics through independent study. Consider this. We teach over 25,000 students from all over the United States and in over 70 foreign countries. And we've been doing it for over 50 years, helping thousands of men and women get started in electronics careers.

We offer flexible training to meet your needs. You can start at the beginner level or, if you already know something about electronics, you may want to start at a higher level. But wherever you start, you can go as far as you like. You can even earn your Associate in Applied Science Degree in Electronics.

Let us get you started today. Just call toll-free 1-800-321-2155 (in Ohio, 1-800-362-2105) or mail in

Circle (3) on Reply Card

the handy reply coupon or card below to:
Cleveland Institute of Electronics,
1776 East 17th Street, Cleveland, Ohio 44114.

CIE World Headquarters

Cleveland Institute of Electronics, Inc.
1776 East 17th Street • Cleveland, Ohio 44114

Please send your independent study catalog.
For your convenience, CIE will try to have a representative contact you — there is no obligation.

Print Name _____

Address _____ Apt. _____

City _____ State _____ Zip _____

Age _____ Area Code/Phone No. _____

Check box for G.I. Bill bulletin on Educational Benefits

Veteran Active Duty **MAIL TODAY!**

Just call toll-free 1-800-321-2155 (in Ohio, 1-800-362-2105)

AES-37

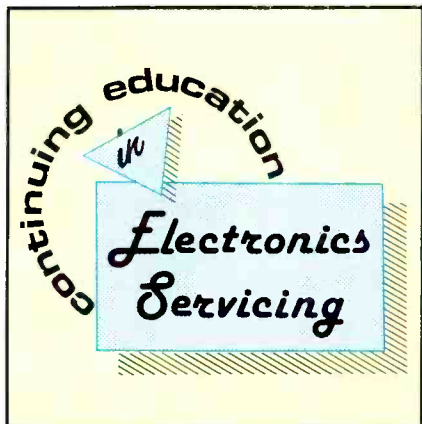

Page 12

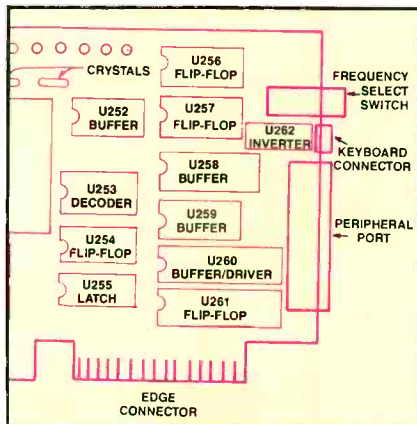

Page 20



Page 37

SPECIAL ADVERTISING SUPPLEMENT

Replacement Parts Showcase

37 Choosing your replacement parts supplier

If you've ever dealt with the frustration of needing that one replacement part yesterday, but you have to worry about minimum orders, jammed ordering lines or long shipping delays, you know what you don't want in a parts supplier. Here are a few questions to ask when you're wondering what you do want. Once you know the important questions, turn to the nine company profiles. You might find some answers.

FEATURES

12 A New-Technology Survival Guide

By Conrad Persson
You might be the type of person

THE MAGAZINE FOR CONSUMER ELECTRONICS SERVICING PROFESSIONALS
ELECTRONIC
Servicing & Technology

who likes to seek out and conquer new technology, but sometimes you're lucky to just *survive* the encounter. Here are a few tips that might help you live to meet another technological challenge.

20 Servicing Zenith Microcomputers

By John A. Ross
If you got hooked with last month's discussion of the Zenith backplane design, Part II's examination of the microcomputer anatomy — an introduction to the central processing unit — should keep you happy. After all, the backplane may be the computer's nervous system, but the CPU is the brains of the system.

DEPARTMENTS

- 4 Editorial
Changes in Readers' Exchange
- 6 Literature
- 8 Business Corner
Choosing Your Marketing Message
- 10 Feedback
- 14 Test Your Electronics Knowledge
- 15 News

16 Troubleshooting Tips

18 Products

24 Symcure

27 Profax

52 Video Corner

Using Logic in Troubleshooting — Part II

54 Audio Corner

Troubleshooting Problems in the De-emphasis circuit — Part II

56 Computer Corner

Time/Date Battery Problems in IBMs

58 Readers' Exchange

60 Advertisers' Index

ON THE COVER

Finding the right replacement parts can mean the difference between a prompt repair turnaround and a TV gathering dust on your hold shelf. And when you have a customer doing without his only color TV, that can mean the difference between a satisfied customer and a former customer. (Photo courtesy of ORA Electronics, a replacement parts supplier based in Chatsworth, CA.)

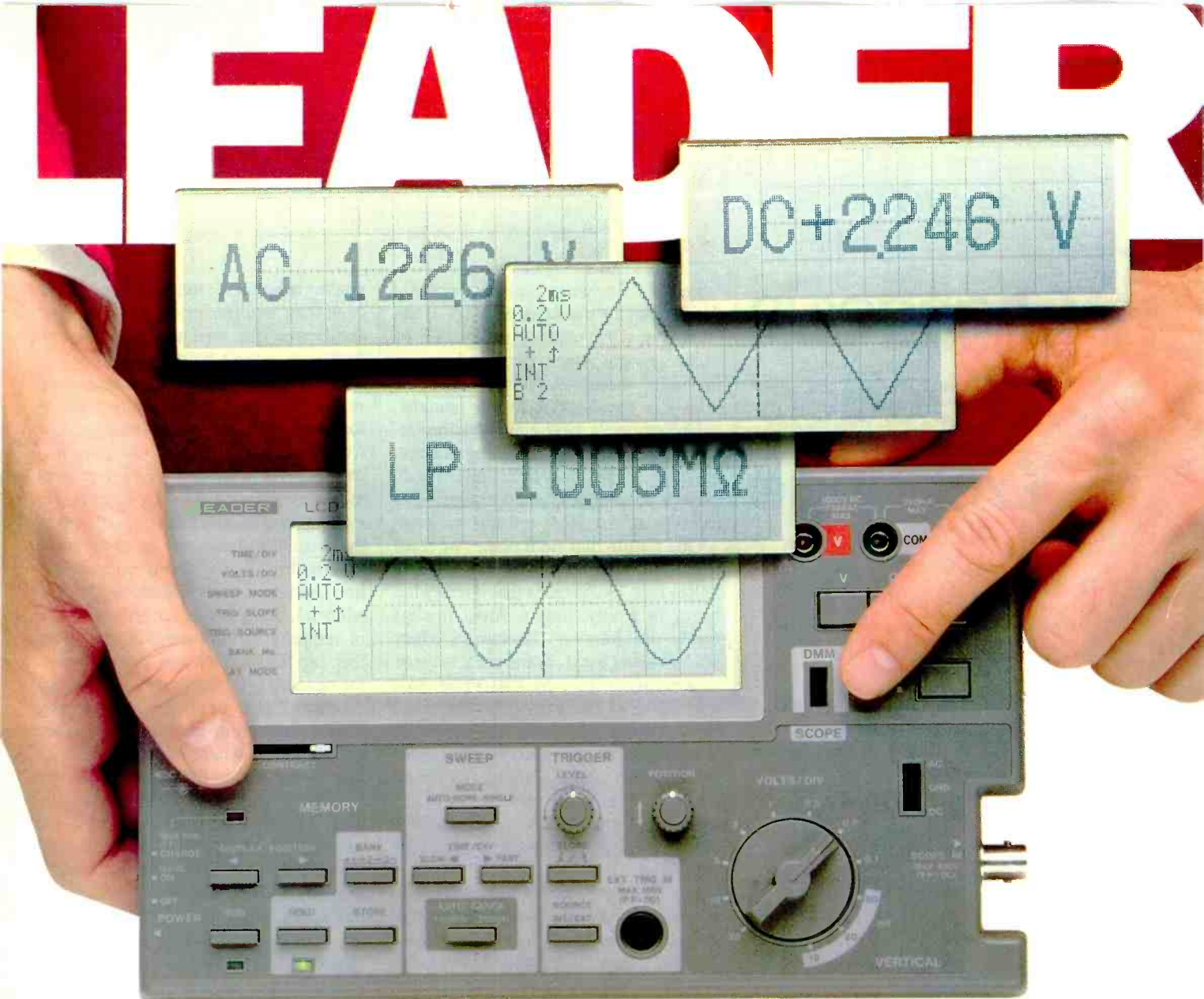

Portable Problem Solvers

Carry the performance today's technology requires. Not the bulk.

These are the hand-held, ultra-compact digital storage oscilloscope/digital multimeters that fit in small tool kits or attaches. And they're both battery and ac-powered.

Multi-function 3MS/s DSO.

Flip a switch to SCOPE. Capture and analyze single-shot and very slow phenomena. Store from three to six waveforms, plus auto-ranging time base setting, pre-trigger roll mode, and on-screen readout of setting conditions. Low power indicator on screen, plus separate memory back-up, built-in.

Full-function, 3 1/2-digit DMM.

Flip back to DMM for precise ac/dc voltage, current and resistance measure-

ments. Large, high-contrast easy to read display. Automatic range selection.

Leader gives you choices.

Single-Channel LCD-100 Unique combination of features and abilities provides ideal service anywhere.

Model 100P, with built-in printer inter-

face, comes with thermal printer.

Two-Channel Model 200 Even more features and memory range: X-Y capability, auto-ranging for vertical and horizontal, and up to 6 waveforms in memory with push-button throughout. Accepts optional **Model 710 Thermal Printer**, for hard-copy documentation.

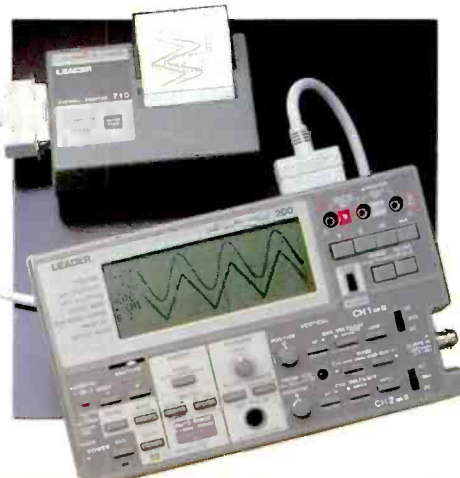

Call toll-free
1 800 645-5104
In NY State
516 231-6900

Leader Instruments Corporation
380 Oser Avenue, Hauppauge, New York 11788
Regional Offices:
Chicago, Dallas, Los Angeles, Boston, Atlanta
In Canada call Omntronix Ltd. 416 828-6221

LEADER

FOR PROFESSIONALS WHO KNOW
THE DIFFERENCE

For Information Circle (4) on Reply Card
For Demonstration Circle (5) on Reply Card

Changes in Readers' Exchange

Readers' Exchange has been a popular department for a number of years. It has been a way for readers to buy, sell or exchange equipment, parts and servicing information. We've been happy to offer this free service to our readers.

Unfortunately, beginning with the October 1989 issue, we are going to begin charging for Readers Exchange. We do so with deep regret, and with apologies to our readers. Here are the reasons.

One reason that we feel that we must begin charging for what was once free in Readers' Exchange is that it really has been, in a way, unfair. Most readers rarely use Readers' Exchange. Many readers never use it. Some readers abuse it, sending in lengthy lists of for-sale items almost every month. For those readers who don't take advantage of Readers' Exchange, it is a waste of space that could be used for articles. By charging for Readers' Exchange, we can assure that the people who receive the benefit of this space are the ones who pay for it.

For those who choose to use it, one of the benefits of the new system is that the items they send in will be printed exactly as they are submitted, and in the month in which the reader specifies. In the current situation, items must be edited and shortened to fit in as many as possible. In fact, because items are published whenever space is available, they often run three or four months after being submitted.

Another benefit is we will be able to better organize items by the type of service wanted or offered. Wanted and for sale items for equipment and service literature will continue to run in Readers' Exchange. Other items, such as jobs wanted or services offered, will continue to run in Classifieds. However, some items never quite fit either category. For example, readers sometimes used the Wanted section of Readers' Exchange to ask for information on where to find parts. The drawback was that

readers who aren't interested in buying or selling equipment often didn't read the department, so a lot of potential information wasn't being exchanged.

Because a charge on exchanging help would even further stop the flow of information, we will be instituting a new free service, called Information Exchange, that will offset the requirement to pay for Readers' Exchange items. We mentioned it in our June editorial, citing the difficulty that many of our readers have had in finding servicing information and repair parts. In response to that editorial, many of our readers have sent in requests for information on where they can find servicing manuals or parts for obscure (and some not so obscure) products. Not only that, but many readers have sent in information they have found on where other readers may find some of this information.

This Information Exchange department will begin next month. We will list information requested — and information provided — for all of our readers to share. This department will eliminate much of the need for individual items that had been published previously in Readers' Exchange.

Compliments to our readers

While we're on the subject of information exchange, I'd like to take this opportunity to say that I think the readers of **ES&T** are some of the most generous, thoughtful people I have ever associated with. Many of you have already sent in information in response to the June editorial, with the sentiment that "perhaps this will help some other technician who is frustrated because he can't find this information." You guys are great. Thanks to all of you who are willing to help your fellow technicians in this way.

Nile Conrad Pearson

FLUKE



PHILIPS



The new 80 Series is a digital meter, an analog meter, a frequency counter, a recorder, a capacitance tester, and a lot more.

It's the first multimeter that can truly be called "multi" ... not only standard features, but special functions usually limited to dedicated instruments.

Plus, innovations only Fluke can bring you. Like duty cycle measurements. Or recording the minimum, maximum and average value of a signal. Or the audible MIN MAX Alert™ that beeps for new highs or lows.

There's even Fluke's exclusive Input Alert™, that warns you of incorrect input connections. And a unique Flex-Stand™ and protective holster, so you can use the 80 Series almost anywhere.

Make sure your next multimeter is truly multi. Call today at 1-800-44-FLUKE, ext 33.

FROM THE WORLD LEADER IN DIGITAL MULTIMETERS.



FLUKE 83	FLUKE 85	FLUKE 87
Volts, ohms, amps, diode test, audible continuity, frequency and duty cycle, capacitance, Touch Hold™, Relative, protective holster with Flex Stand™	Volts, ohms, amps, diode test, audible continuity, frequency and duty cycle, capacitance, Touch Hold™, Relative, protective holster with Flex Stand™	Volts, ohms, amps, diode test, audible continuity, frequency and duty cycle, capacitance, Touch Hold™, Relative, protective holster with Flex Stand™
\$189*	\$229*	\$289*
0.3% basic dc accuracy	0.1% basic dc accuracy	0.1% basic dc accuracy
5 kHz acV	20 kHz acV	20 kHz acV
Analog bargraph & zoom	Analog bargraph & zoom	High resolution analog pointer
Three year warranty	Three year warranty	True rms ac
		1 ms PEAK MIN MAX
		4 1/2 digit mode
		Back lit display
		Three year warranty

*Suggested U.S. list price

The new Fluke 80 Series shown actual size

John Fluke Mfg. Co., Inc. P.O. Box D9090 M/S 250C, Everett, WA 98205
 U.S.: 206-336-5400 CANADA: 416-890-7600 OTHER COUNTRIES: 206-355-5500
 © Copyright 1989 John Fluke Mfg. Co., Inc. All rights reserved. Ad No. 0591-F80

FLUKE

Circle (6) on Reply Card

www.americanradiohistory.com

Electronics product catalog

A 528-page catalog from *Joseph Electronics* offers thousands of products from more than 125 brands. Parts, supplies, test instrument, electronics products in more than 150 categories are included. For a free copy, contact the company at 8830 N. Milwaukee Ave., Niles, IL 60648; 800-323-5925 (312-297-4200 in Chicago).

DSO technology video

John Fluke Manufacturing is offering an 11-minute video that discusses digital storage oscilloscope (DSO) advantages, specifications and ease-of-use features. "DSOs With A Difference" studies the use of the PM 3335, 3350 and 3365 series of medium frequency analog/digital storage oscilloscopes, which combine digital storage capability with easy-to-use analog functions.

Circle (125) on Reply Card

Tool and test equipment catalog

HMC's 1989 spring and summer catalog includes test instruments, tool kits, soldering/desoldering systems, lamps and magnifiers, anti-static products and precision hand tools. The previous edition of this catalog won the Gold Award from *Catalog Age* magazine during its annual American Catalog Awards.

Circle (126) on Reply Card

4c connection folder

Micro-Circuits is offering the 4c93 data folder covering four different aspects of the new 4c connection technology. The first section lists seven major situations under which the elimination of intermittent electrical connections can reduce operating costs and unreliability. The second section lists four opportunities created by the technology. The third section explains the electronic mechanism by which the 4c materials eliminate intermittent connections. The fourth section illustrates how electronic repair services and their clients can reduce costs by using the new technology.

Circle (146) on Reply Card

Electronics industry review

The *Electronic Industries Association Consumer Electronics Group* (EIA/CEG) is offering its 1989 Annual Review — Entertainment and Education, Yesterday, Today and Tomorrow. The review is a profile and history of

this rapidly changing, \$43-plus billion industry at retail. It traces the development of consumer electronics product categories and provides statistics on industry-wide sales trends.

Circle (147) on Reply Card

Engineering guides

Echelon Industries has produced a set of engineering guides that can be used to assist engineering, manufacturing and maintenance staff in solving various cleaning, contact lubricant and conformal coating-related problems using the company's Electrolube line. The Electrolube line of products provide the industry with a range of aerosols and cleaning products that contain no CFCs (chlorofluorocarbons).

Circle (148) on Reply Card

Test instrument catalog

A broad range of hand-held digital and analog multimeters with bar graph indicators are among more than 50 new products being featured in the SOAR test instrument catalog from *C.G. Instruments*. The 44-page catalog also details digital clamp-on meters, bench DMMs, frequency counters, insulation and earth/insulation resistance meters, a number of digital thermometers, a 15MHz dual-trace portable oscilloscope, adapters, accessories and cases.

Circle (149) on Reply Card

Scope probes note

An application note describing oscilloscope probes and techniques for measuring surge voltages to 6kV is being offered by *KeyTek Instrument*. The application note provides detailed information on using high-voltage oscilloscope probes to measure high-voltage surge transients with front times as fast as 10ns. Probe impedances, physical size and other considerations are also discussed.

Circle (150) on Reply Card

Passive static eliminator catalog

Chapman is offering a free technical publication on passive static eliminators, featuring its new static eliminating brush, the Passivator. The publication details the performance of the Passivator vs. other types of static brushes. It also explains the overall theory of passive brush effectiveness in various applications.

Circle (151) on Reply Card

Electronic Servicing & Technology is edited for servicing professionals who service consumer electronics equipment. This includes service technicians, field service personnel and avid servicing enthusiasts who repair and maintain audio, video, computer and other consumer electronics equipment.

EDITORIAL

Nils Conrad Persson, *Editor*
Tom Cook, *Senior Managing Editor*
Alisa Carter, *Associate Editor*
Andrew Naugher, *Editorial Assistant*

CONSULTING EDITORS

Carl Babcock, *Consumer Servicing Consultant*
Homer L. Davidson, *TV Servicing Consultant*
Christopher H. Fenton, *Circuit Fabrication Consultant*
William J. Lynott, *Business Consultant*
Victor Meelidijk, *Components Consultant*
Kirk G. Vistain, *Audio Consultant*
Sam Wilson, *Electronics Theory Consultant*

ART

Barbara Miles, *Graphic Designer*

BUSINESS

Cameron Bishop, *Group Vice President*
Eric Jacobson, *Group Publisher*
Greg Garrison, *Sales Manager*
Kevin Callahan, *Creative Director*
Marcia Durrett, *Marketing Director*
Evelyn Hornaday, *Promotions Manager*
Darren Sextro, *Promotions Coordinator*
Dee Unger, *Advertising Business Manager*
Catherine Grawe, *Advertising Coordinator*

ADVERTISING

Greg Garrison, 913-888-4664

ADMINISTRATION

R.J. Hancock, *President*
Chuck Rash, *Corporate Circulation Director*
Sandra Stewart, *Circulation Director*
Donna Schlagle, *Circulation Manager*
Customer Service, 913-541-6628

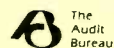

Member, Audit Bureau of Circulation



Member, American Business Press



Member, Electronic Servicing Dealers Association

CORRESPONDENCE

Editorial, advertising and circulation correspondence should be addressed to: P.O. Box 12901, Overland Park, KS 66212-9981 (a suburb of Kansas City, MO); 913-888-4664. Home office fax: 913-541-6697. Home office telex: 42-4156 INTERTEC OLPK

SUBSCRIPTION PRICES: one year, \$19.49; two years, \$32.98 in the USA and its possessions. Foreign countries: one year, \$23.49; two years, \$36.98. Single copy price: \$2.50; back copies, \$3.00. Adjustment necessitated by subscription termination to single copy rate. Allow 6 to 8 weeks for new subscriptions.

PHOTOCOPY RIGHTS: Permission to photocopy for internal or personal use is granted by Intertec Publishing Corp. for libraries and others registered with Copyright Clearance Center (CCC), provided the base fee of \$2 per copy of article is paid directly to CCC, 21 Congress St., Salem, MA 01970. Special requests should be addressed to Eric Jacobson, publisher. ISSN 0278-9922 \$2.00 + 0.00

Electronic Servicing & Technology (ISSN 0278-9922) is published monthly for \$19.49 per year by Intertec Publishing Corp., 9221 Quivira Road, Overland Park, KS 66215. Second-class postage paid at Shawnee Mission, KS and additional mailing offices. POSTMASTER: Send address changes to ELECTRONIC SERVICING & TECHNOLOGY, P.O. Box 12960, Overland Park, KS 66212.

©1989 by Intertec Publishing. All rights reserved.



Hand Tools With Horsepower!

That's the name of the game

Pick up a Paladin tool and you've got hand tool horsepower to get the job done... *whatever* game you're in.

Your hand will fit Paladin's ergonomically-designed grip like a glove. You always get comfortable, precise tool control everytime you wrap your hand around a Paladin tool! Because Paladin tools feel better in your hand, your hand gets a better feel for the job.

Professionals prefer the variety, versatility and lasting value of Paladin tools... cable preparation tools, strippers, crimpers and cutters, slitters, notchers, screwdrivers; and accessories like connectors, telecom hardware and other valuable service and production aids. Whatever your industry, whatever your need, Paladin has your tool.



If you expect quality, reliability, performance and productivity from your hand tools, demand Paladin. Serving the electronic, electrical, telecommunications and various other industries for more than 10 years, we understand your specialized requirements, and have precision-engineered and patented sol-

utions for almost every application.

The Only Game In Town

Feel the hand-held horsepower for yourself with Paladin tools. Check us out for comfort, quality, versatility, and pure spirit of performance. You'll discover...when you put Paladin energy in your hand, every job becomes a little easier.

It's your move...contact us for the authorized distributor near you. Remember, Paladin

is the only game in town!



At work with professionals every day

PALADIN CORPORATION
3543 Old Conejo Road, Suite 102
Newbury Park, CA 91320
(805) 499-0318 - FAX (805) 499-4006

A member of the Weidmüller group of companies

Circle (29) on Reply Card

Choosing your marketing message

By William J. Lynott

Anyone who's been in the electronics service business for 10 to 20 years has seen the profound changes that can take place within a single decade. Most obvious are the stunning technological advances that have altered the industry at a breathless pace over each of the past decades.

Starting in the 1940s with the introduction of commercial TV and the 1950s with the birth of the transistor, each new decade since then has ushered in its own series of rapid-fire technological breakthroughs. In that regard, the 1990s is likely to be no different than its predecessors. The decade will begin with an introduction to high definition TV (HDTV). Where it will end is anyone's guess.

But technology isn't the only way the service industry changes and grows. Though they may not be quite so evident and dramatic, changes in the business side of things have been equally important to the survival and growth of electronic service dealers. Each major change in technology brings with it subtle but important imperatives for change in management techniques. The 1990s is sure to have more than its share of this sort of change.

Marketing strategies

In the '70s and particularly in the '80s, the need for service dealers to diversify became dramatically evident. Most of those who would not or could not heed the warnings to branch out from basic TV service are now only memories. Although diversification will continue to be just as important in the '90s, the next few years will see changes that will make other considerations even more important. The need to improve marketing skills is one of those.

If you're a typical electronics service

dealer, your potential customers have a wide choice of whom to call when they need service. Despite the thinning out of service dealer ranks in recent years, there is still a ton of competition out there in most communities. The next crop of survivors in the service business will be those who learn how to separate themselves from the crowd — make themselves distinctive, uniquely recognizable. For the most part, that will mean learning and using the latest service marketing techniques.

Market your customer satisfaction

Although not everyone recognizes it, offering exceptional service to the customer is one of the most effective and timely marketing techniques available to the service dealer.

An interest in customer satisfaction is one aspect of management that has seriously declined in American business over the past decade or two. But don't be misled by that. Don't get caught in the ambush that is going to snare a horde of complacent business people during the '90s.

Customer satisfaction, like most elements in our society, is subject to what I call the pendulum influence. Once a pendulum swings in one direction to its maximum amplitude, it can only pause for a moment and then reverse its course. The arc described by the pendulum in a clock is very short, but the arc that must be traveled by the imaginary pendulum of societal change is long indeed. It took a very long time for service to reach the depths that it has in this country, so the trip to the other end of that arc will be a long one.

But the journey has already begun. American consumers have reached the limit of their patience with rude, ill-trained, uninterested employees. Servicers who are perceptive enough to hear their customers know they have had enough, and they expect and will accept

nothing less than the quality of service to which they are entitled.

The interest in and dedication to customer satisfaction you can expect to see during the '90s hasn't been seen for a good number of years in our society. There are already plenty of clues to what is happening. Instead of powerless figureheads, major corporations are putting corporate officers with muscle in charge of their customer service activities. Smaller companies are doing even better by responding quickly to the new demands of busy consumers. Service at the customer's convenience is already a byword at the most progressive service companies.

And so, one of the most effective of all marketing tools in the '90s will be a policy that puts your company in the forefront of the new emphasis on customer satisfaction. Not just superficial talk, but genuine action that places your customers' needs at the top of every employee's list of priorities. That will be the best and the most dramatic way to separate you from your competition.

For most people, price will always be a consideration in the selection of a product or service. But it's very important for a service dealer to understand that price is *not* at the top of the priority list when the typical customer (consumer or business) selects a service dealer. Despite the increasing costs associated with servicers these days, every major service industry study gives us the same message: the quality, promptness and dependability of services rendered are more important to the consumer than the price charged.

When all of these considerations are put together, it becomes obvious that the road to continued success in the 1990s is not going to be paved with the strident claims about the lowest price in town. Instead, the service dealer who understands the need to excel in quality of service will prevail. ■

Lynott is president of W.J. Lynott, Associates, a management consulting firm specializing in profitable service management and customer satisfaction research.

**When you come up with
a superior product,
people talk.**

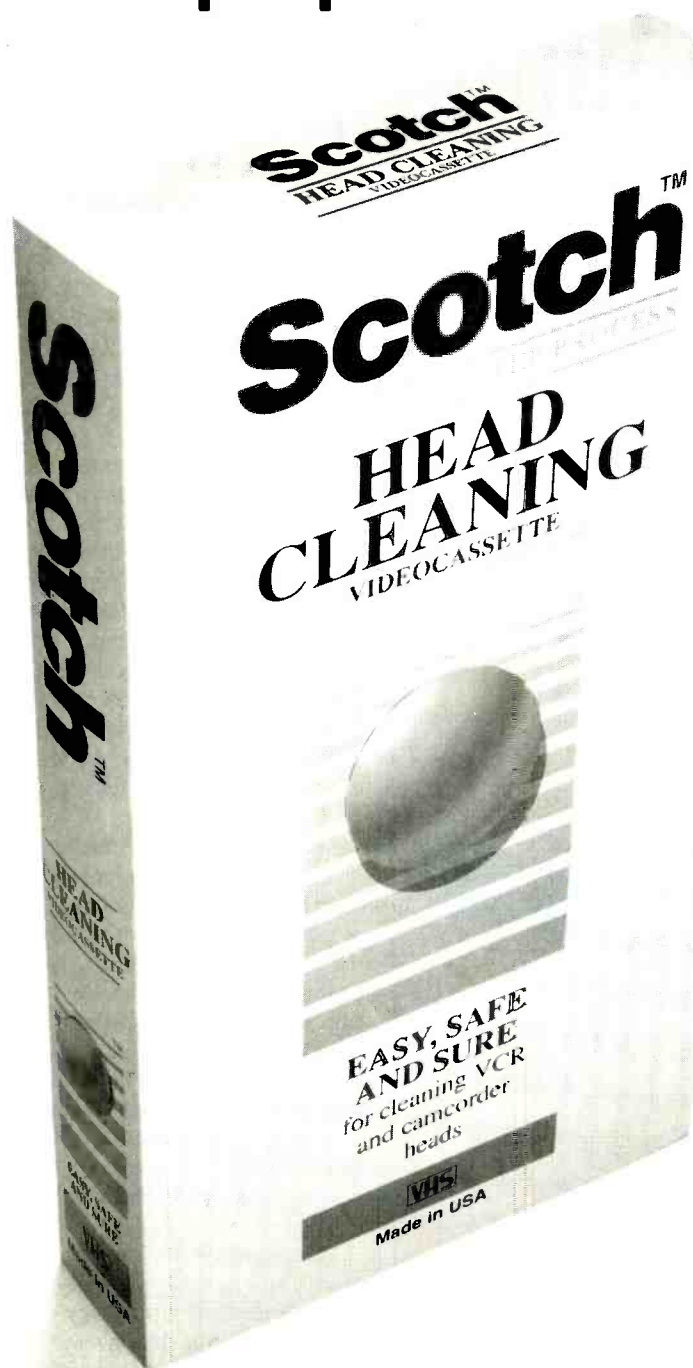

“This is the first head cleaning system I feel confident I can recommend.”
George Bluze, CET/CSM, Largo, FL

“We sell it and recommend it.”
Don Erwin, CSM, San Diego, CA

“Protects my customers’ investment and my reputation.”
Art Nelson, CET, Milwaukee, WI

“It works better than traditional wet or dry methods.”
John Sperry, CET/CSM, Lincoln, NE

“A quality product and safe to use.”
Bill Warren, CET/CSM, Knoxville, TN

“Great product...it’s safe and effective.”
George Weiss, CSM, Chicago, IL

NESDA experts agree the best solution to cleaning video recorder heads is the simplest. Unique to its category, the Scotch™ Head Cleaning Videocassette is the only recorded magnetic tape-based head cleaning cassette.

“It’s effective, it’s safe and it’s economical.”
As featured in the Advance Technology Nov./Dec. ’87 supplement

Call 1-800-443-6975 to order the Scotch Head Cleaning Videocassette model SCO-3198-4.

You may obtain information by writing:
3M Consumer Video and Audio Products
Division, Building 223-5N-01, 3M Center,
St. Paul, MN 55144-1000.

**Scotch™ Head Cleaning Videocassettes.
Easy. Safe. Sure.**

Time/date battery problems in IBMs

By Glenn Patsch

Did you ever wonder how a personal computer knows the date and time? If you look at the files on a computer with the directory (DIR) command, you will see a date and time for all the files listed. The DATE command will display the current day of the week and the date as mm-dd-19yy. The TIME command will display the current time as hh:mm:ss:xx in 24-hour format (1 p.m. is 13:00). The .xx in the time is hundredths of a second. Although both commands prompt you to enter a new date or time, if you just press ENTER, the current date or time will be unchanged. This method allows you to just display the date or time without changing it.

Clock configurations

The IBM PC and PC/XT did not come with a time-of-day clock. Most add-on boards like the AST SixPak and I/O Mini include a clock run by a small button cell. These are usually 3V lithium button cells (BR2325) expected to last about one year. I have found they usually last about two years with frequent use of the PC. The battery is used only when the PC is turned off. Another brand of add-on boards, Quadram Quadboards, have a nickel-cadmium (NiCd) battery that does not usually need to be replaced.

These add-on boards come with software for setting the clock. AST has ASTCLOCK and Quadram uses PWRUPCLK software to set the clock. I have found the clocks to be very accurate and require resetting only when daylight savings time arrives and when the battery needs replacing. In cases where a PC doesn't have a clock, the date and time can (and should) be set each time the PC is turned on by responding to the DATE and TIME commands.

The IBM PC/AT comes with a built-in clock. The PC/AT uses a rectangular 6V battery with a connecting cable to

the main CPU board. The battery is attached to the inside back of the unit above the keyboard connector. This is the same style of battery you will most likely find in any of the IBM compatible systems. The IBM PC/AT also uses the battery to power the clock and a small CMOS memory that stores configuration information about the type of

diskettes and hard disks attached. If the battery fails, you can use the diagnostics disk to reset the date, time and configuration information.

The IBM PS/2 comes with a built-in clock that uses a 6V lithium battery (IBM part number 72X8498). The battery is on the front left for the small desktop units (models 30, 50 and 70) and on the bottom front side near the speaker for the floor-standing models 60 and 80. The battery is also used to power a small CMOS memory that retains the setup information for the system. The PS/2 configuration is completely controlled by software: No switches need to be set on the CPU board. The configuration software is on the reference diskette included with each system. You can reset the time and date with the TIME and DATE commands, or you can use the reference diskette software.

Changing the battery

When you change a battery in one of these computers, you have about 20 minutes to complete the change before the information in memory is lost. The best approach is to run the configuration software and make sure the configuration information on the reference diskette is current. Then, if the information is lost while you change the battery (or if it fails), the reference diskette has a restore configuration option you can use. Using this option to restore a configuration can save you a lot of time.

Whenever you're servicing a PC, always suspect that a battery may have failed. I have seen a battery fail in less than six months. If a customer brings in a PC for repair, I make it a habit to also change out the battery if it hasn't been replaced in a year. To keep track of battery life, put a small sticker inside the PC cover or near the battery with the date of last replacement. The next time someone services the PC, that information will be readily available. You could also put the battery replacement date in a PC file called equip.dat along with information on the hardware, purchase date and servicing record. ■

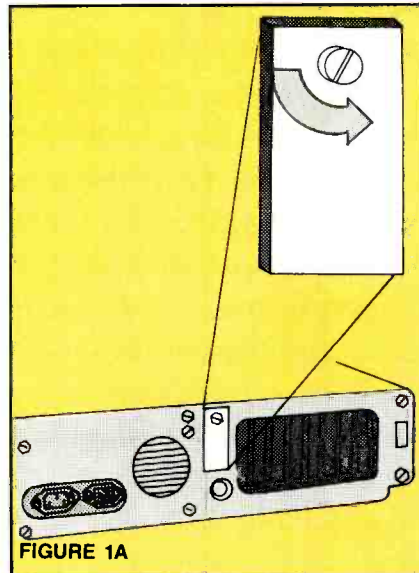

FIGURE 1A

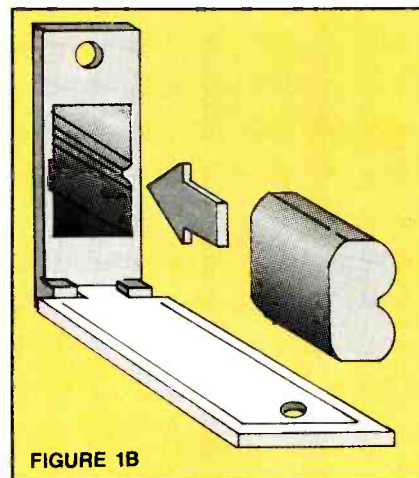

FIGURE 1B

Figure 1. To install a battery in the IBM PC/XT, the servicer must first turn off the system and all external options, then remove the screw that closes the battery compartment (Figure 1A). The battery slides in as shown in Figure 1B, with the terminal end first.

Patsch is a consultant specializing in the selection, evaluation and installation of IBM personal computer and compatible hardware and software.

PC Troubleshooting and Repair Products and Services

from

Windsor Technologies



PC-Technician

A complete family of diskette-based diagnostic systems for IBM PCs and compatible computers.

WindsorPOST

A family of unique ROM-based diagnostic products for service shop and repair depot.

Education and Documentation Services

Comprehensive standard or custom classroom-based computer repair and troubleshooting training, plus service documentation support.

Windsor Technologies, Inc.

130 Alto Street,
San Rafael, California 94901
(415) 456-2200
FAX: (415) 456-2244

Mail to: **Windsor Technologies, Inc.**

130 Alto Street, San Rafael, CA 94901
(415) 456-2200; FAX: (415) 456-2244

Please send me the following:

FREE PC-Technician Evaluation Diskette:
IBM PC, PC XT, PC AT
IBM PS/2 Group

WindsorPOST information
Windsor Education & Documentation Services information

NAME _____ TITLE _____

COMPANY _____ TELEPHONE _____

ADDRESS _____

CITY _____ STATE _____ ZIP _____

SERVICE CO. OEM MANUFACTURER DEALER VAR/VAD

IN-HOUSE SERVICE USER OTHER _____

PC-Technician and WindsorPOST are trademarks of Windsor Technologies, Inc., and IBM PC, PC XT, PC AT are trademarks of International Business Machines Corporation.

ES&T 0889

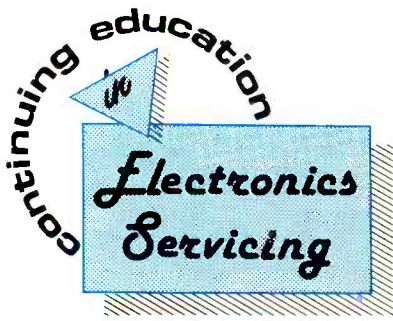

A new-technology survival guide

By Conrad Persson

When the first iron sword made mincemeat of one wielded by an adherent of the bronze age, the guy with the mangled bronze sword probably recognized the need to educate himself on this new technology. (If he *survived* his first encounter with the new technology, that is.) He almost certainly wasn't the first to realize he wasn't keeping abreast of his chosen field, and he definitely wasn't the last.

The point is that the need to constantly learn about developing technologies that affect your field of interest is not a phenomenon peculiar to today. It has always been so. The horse gave way to the steam engine, which in turn gave way to the internal combustion engine. The scribe gave way to the printing press. Those people who were either using or servicing these products had to change to keep up with the times. History is full of stories about changing technology and humanity's struggle to keep up with it. It just seems to happen a lot faster now.

To some extent, each of us can choose how to react to the almost constant technological change that occurs today. Some choose not to deal with it at all — you've probably heard stories about people who bought a new VCR years ago and still have a clock that blinks 00:00 because they won't read the instructions. That's all right if that individual's livelihood doesn't depend on an understanding of that technology, but it won't work for a consumer electronics servicing technician.

With that as a given, how does a technician keep up with the new consumer electronics technology that's constantly bombarding us?

Persson is editor of *ES&T*.

Training and literature

A great deal of help is available to technicians who want to learn about some of the newest technologies in consumer electronics products. A lot of people stand to benefit if technicians know how to fix today's complex electronic products. Manufacturers want competent technicians trained to fix their products when they break. Technical schools benefit by offering courses that attract students who want to learn the new technology. Book publishers can sell a lot of books if they publish good texts that help technicians understand and fix consumer electronics products.

Doing it

Most consumer electronics servicing technicians, overwhelmed by the new technology, are aware of the need to upgrade their skills. The problem boils down to answering two questions: "What do I need to learn?" and "How do I go about learning it?"

It's important to analyze these questions thoroughly in order to establish specific goals. You can't just say "I need to learn more about VCRs" and then charge off to try and learn about them. It's important to decide whether you just want an overview on VCR technology, or if you have a pretty good idea of how VCRs work and now need some instruction in specific areas.

Self study

One simple (although not always effective) method of learning about the new technology is to buy a book on the subject and study it yourself. Depending on a number of factors, including the complexity of the subject, the quality of the book, and your own self-discipline,

this experience might result in anything from complete understanding of the material to a complete waste of time. Home-study courses offer a major improvement over studying from books. The material is broken down into study units, someone tells you what is expected of you, and you get feedback through regular tests.

Schools and seminars

If time and money permit, a more effective way to learn is through classroom-type courses. Again, there are many avenues. Public and private technical schools offer courses from the most elementary introductory courses to detailed theory and design. Check at your local community college to see if it offers such courses.

If you have the time and budget to travel, manufacturers offer schools and seminars on the operation and servicing of specific items. Manufacturers of test equipment and tools such as multimeters, oscilloscopes and soldering tools also offer instruction in using their products. Some have books and pamphlets that help you understand what you can do with their products. Others offer formal courses of study (some to do at home), and some offer courses and seminars that travel to different areas of the country so you can take a formal course taught by the experts near home.

Identifying resources

A local school may have the course you need. One of the book publishers might have just the book or series of books to fill in the gaps in your knowledge. One of the associations related to home-electronics equipment-manufacturing sales or service may have just the item of information you need,

Trade associations

Electronic Industries Association/
Consumer Electronics Group
2001 Eye St. N.W.
Washington, DC 20006
202-457-4919

Electronics Representatives Association
20 E. Huron
Chicago, IL 60611
312-649-1333

Electronic Technicians Association
604 North Jackson St.
Greencastle, IN 46135
317-653-3849

Musical Instrument Technicians
Association, International
8216 Audrain Drive
St. Louis, MO 63121-4504
314-389-3290

National Association of Business and
Educational Radio
1501 Duke St., Suite 200
Alexandria, VA 22314
703-739-0300

National Association of Retail Dealers of
America
National Association of Service Dealers
10 E. 22nd St.
Lombard, IL 60148
312-953-8950

National Electronic Distributors
Association
35 E. Wacker Drive, Suite 3202
Chicago, IL 60601
312-558-9114

National Electronic Servicing Dealers
Association

2708 W. Berry St.
Fort Worth, TX 76109
817-921-9062

Technical book publishers

Hayden Book Company
4300 W. 62nd St.
Indianapolis, IN 46268
317-298-5400

McGraw-Hill Book Company
1221 Avenue of the Americas
New York, NY 10020
212-512-2000

Prentice-Hall
Rt. 9W
Englewood Cliffs, NJ 07632
201-592-2455

Howard W. Sams & Company
4300 W. 62nd St.
Indianapolis, IN 46268
317-298-5400

Tab Books
P.O. Box 40
Blue Ridge Summit, PA 17214
717-794-2191

Van Nostrand Reinhold Company
135 W. 50th St.
New York, NY 10020
212-254-3232

Home study

Cleveland Institute of Electronics
1776 E. 17th St.

Cleveland, OH 44114
216-781-9400

Cook's Institute of Electronics
Engineering
Desk 15
P.O. Box 20345
Jackson, MS 39209
601-371-1351

Electronic Institute of Brooklyn
4823 Avenue N
Brooklyn, NY 11234
718-377-0369

Grantham College of Engineering
10570 Humbolt St.
Los Alamitos, CA 90720
213-493-4421

Heath/Zenith
P.O. Box 167
Hilltop Road
St. Joseph, MI 49085
616-982-3215

National Technical Schools
456 W. Santa Barbara Ave.
Los Angeles, CA 90037
213-234-9061

NRI Training for Professionals
McGraw-Hill Continuing Education
Center
3939 Wisconsin Ave.
Washington, DC 20016
202-244-1600

Private trade schools

National Association of Trade and
Technical Schools
2251 Wisconsin Ave. N.W.
Washington, DC 20007
202-342-3689

or they may be able to point you in the right direction.

The sidebar accompanying this article lists a number of correspondence schools, book publishers and associations you might want to contact for further information on what educational opportunities they have to offer.

EIA/CEG courses

A good place to start when you're looking for information on servicing some of the new consumer electronics products is the Electronic Industries Association/Consumer Electronics Group (EIA/CEG). This is the organization to which most of the large manufacturers of consumer electronics products belong. The EIA/CEG Product Services Division has the task of developing training programs to ensure that there will be enough competent technicians to service the consumer electronics products of today and tomorrow. This organization offers a number of educational opportunities to any individual currently employed as a consumer electronics servicer. For example, CEG offers courses that consist of classroom and laboratory sessions on servicing VCRs and CD players, and a combination of microprocessor and compact disc (mp/cd).

These courses are ordinarily a week long, and they're free to qualified technicians. The technician, or the facility sponsoring him, is responsible for his own transportation, food and lodging.

In addition to these resident courses, the product services division also offers, for a nominal fee, a number of videocassette tapes that educate technicians in a number of areas. Here is a partial list:

- Multi-channel TV sound.
- Troubleshooting with modern electronic test equipment.
- Professional car audio installation.
- Basic car audio installation.
- High-technology soldering.

Write to the EIA/CEG for further information. (See the accompanying sidebar for the address.)

Whatever method you use for continuing your electronics servicing education, you'll be preserving your future if you try to stay abreast of changes. After all, when technology changes, it isn't only the old equipment that can become obsolete. In the fast-paced world of servicing, "surviving" new technology can require a real dedication to new ideas. ■

Test your electronics knowledge

By Sam Wilson, CET

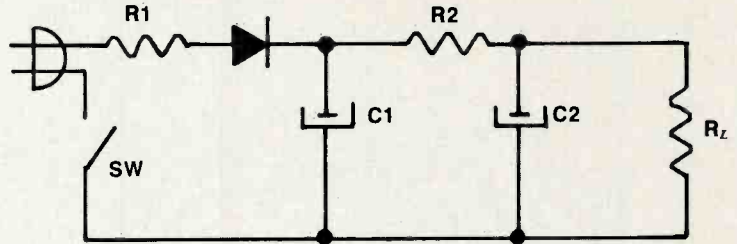

FIGURE 1

In this quiz, we'll present 10 questions that require one word for each answer. All of the answers are in the matrix. They may be horizontal, vertical, at a 45° angle, or backward in any of these configurations. Actually, there are 20 terms related to electronics that are hidden in the matrix, so circle only those that are answers to the questions.

If you don't feel like hunting today, fill in your answers and go directly to the answers on page 17.

Example:

- Q. The control electrode of a bipolar transistor is called the _____.
- A. Base (circled in the matrix)

Clues

1. The temperature surrounding a component is called the _____.

Wilson is the electronics theory consultant for ES&T.

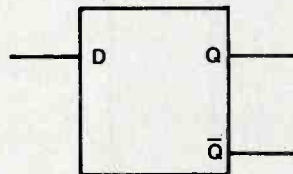

FIGURE 2

temperature.

2. A _____ is a binary digit.
3. A technician who takes tests to demonstrate his ability in electronics is a _____.
4. % _____ = $P_{out}/P_{in} \times 100$.
5. A 4-terminal thyristor that can be turned on or off with gate voltages is known as a _____.
6. The effect of a power supply current is eliminated by connecting thermistors into a _____ circuit.
7. In the half-wave rectifier in Figure 1, resistor R1 is a _____ limiting resistor.
8. A component that is rated by its intrinsic standoff ratio is a _____.
9. The name used to represent eight bits is _____.
10. The type of flip-flop represented by the symbol in Figure 2 is a _____ flip-flop.

Answers are on page 17.

O	I	O	S	U	I	S	L	E	C	C	H	A	G
R	E	F	A	J	C	S	E	E	I	Z	E	X	A
S	G	T	A	T	J	J	H	G	G	S	C	T	H
B	R	R	Y	J	O	J	E	T	V	A	D	O	P
I	U	E	J	B	Z	F	J	B	A	T	I	O	L
T	S	P	Q	W	D	F	M	O	F	E	L	R	A
V	N	U	I	D	N	I	A	X	E	U	W	O	B
V	I	S	Q	B	F	C	M	I	S	B	S	A	V
S	H	M	X	O	H	I	B	I	T	L	L	J	J
H	D	G	B	C	M	E	I	N	R	L	L	K	S
U	A	A	I	Q	D	N	E	U	I	G	J	Q	C
T	T	I	J	J	H	C	N	J	A	D	M	I	S
A	A	N	W	S	I	Y	T	U	C	X	J	X	N
S	E	R	I	E	S	M	U	X	G	T	Y	F	P

EIA/CEG proposes warranty claim format

The Product Services Committee of the Electronic Industries Association's Consumer Electronic Group (EIA/CEG) has developed an electronic filing format for warranty claims. This standardized format is designed to better facilitate the exchange of information between servicers and manufacturers.

The goal is to grow into a universal warranty reporting system whereby servicers could electronically transmit data to manufacturers. The system would benefit manufacturers by eliminating keying in information from handwritten forms (which could also be submitted under the new format). Servicers would benefit with quicker reimbursement. Software systems might be used to alert users to invalid codes.

For more information, call the EIA/CEG's Product Services Department at 202-457-8708.

Subdivision provides forum for home automation

The Electronics Industries Association/Consumer Electronics Group (EIA/CEG) has created the Home Automation Subdivision to provide a forum for companies to promote and support the home automation industry. This branch of the Home Information Equipment Division will advance the interests of companies that plan to manufacture, distribute, research and develop home automation consumer electronics products.

For more information, contact the EIA at 2001 Eye St. N.W., Washington, DC 20006; 202-457-4900.

Newsletter publishes survey

The Service Dealer's Newsletter has released the results of its 1988 readership survey regarding salaries, bonuses, benefits, working conditions and labor charges. The newsletter focuses on management and administrative concerns of the service industry.

For a copy of the survey, contact the Service Dealer's Newsletter at 1400 Easton Road, Roslyn, PA 19001; 800-673-7808.

UL proposes standards

Underwriters Laboratories (UL) has proposed two standards: UL 1950, the Standard for Safety for Information Technology Equipment Including Elec-

trical Business Equipment, and UL 1416, the Standard for Safety for Overcurrent and Overtemperature Protectors for Radio- and Television-Type Appliances.

UL 1950 covers information technology equipment with a rated voltage not exceeding 600V. UL 1416 covers protectors supplied by a 20A or less branch circuit. It does not cover thermal cutoffs.

UL is seeking review and comment to develop a consensus upon which recognition of UL 1950 and continued recognition of UL 1416 by the American National Standards Institute (ANSI) can be based.

Contact Bill Bird (for UL 1950-NR) or L.M. Cohen (for UL 1416-NR) at UL, 333 Pfingsten Road, Northbrook, IL 60062-2096; 312-272-8800. ■

Instrumentation. Cover to Cover.

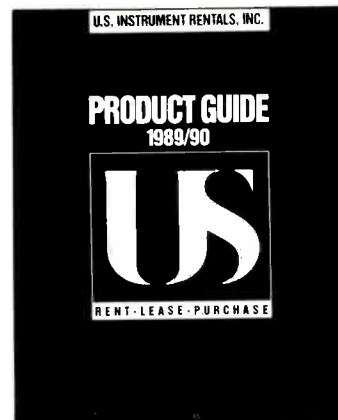

800-824-2873
RENT-LEASE-PURCHASE

With the new 1989/90 Product Guide from U.S. Instrument Rentals that's exactly what you get. This hardbound guide is packed with over 5000 products from more than 170 major manufacturers. Browse through our comprehensive product sections—analyzers, counters, oscilloscopes, microprocessor development systems, computer products, power sources, generators, telecommunications products—and more!

The detailed product descriptions, product photos, and unbiased, thorough product comparison charts help speed your product decisions, and provide you with a valuable reference tool you'll come to rely on. We're sure you'll find this to be the most complete, authoritative guide to instrumentation available.

Call or write for your free copy, and let our 1989/90 Product Guide begin working for you.

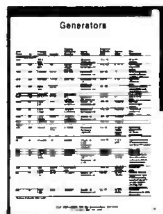

Product Specification Charts



Detailed Product Descriptions with Photos

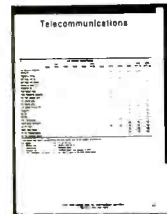

Unbiased Manufacturer's Comparison Charts

United States Instrument Rentals, Inc.



A U.S. Leasing Company
2988 Campus Drive
San Mateo, CA 94403
800-824-2873

Circle (30) on Reply Card

August 1989 *Electronic Servicing & Technology* 15

Troubleshooting Tips

Symptom: Left edge of picture dark

Set ID: GE 25 MB

Photofact: 1400-3

This GE console came into the shop with intermittent UHF reception and intermittent color on all channels. Cleaning the UHF tuner and resoldering several cracked connections at the chroma and low-level video module pin connectors cured those problems.

However, one problem remained. About an inch of the left edge of the picture was black, but the raster was normal when the TV was tuned to an unused channel. This indicated that the video was being affected at the horizontal rate.

I suspected a defective filter capacitor on one of the scan-derived B+ lines feeding the tuner IF or video sections. Using clip leads, I placed a filter capacitor across each supply, one at a time, but the problem was unaffected. The AGC affects the video and receives a horizontal pulse, so I next checked the filter capacitors associated with the AGC stage. All showed acceptable values.

Next followed a long, unfruitful period of checking other possible causes of the missing left-edge video. As I was performing these checks, I noticed that Q303 on the low-level video module was a high-power type (TO-202). The schematic showed Q303 was the first video amp, a low-power stage. Installing the correct replacement (ECG 229) restored the blanked out video at the left edge of the picture.

The owner of this set had bought it second hand and knew nothing of its repair history. Because the solder connections on Q303 were different in appearance from all of the other connections in the set, I assumed that someone else had replaced Q303 at some time in the past and used an incorrect replacement for that transistor.

Alan Detwiler
Rogers, OH

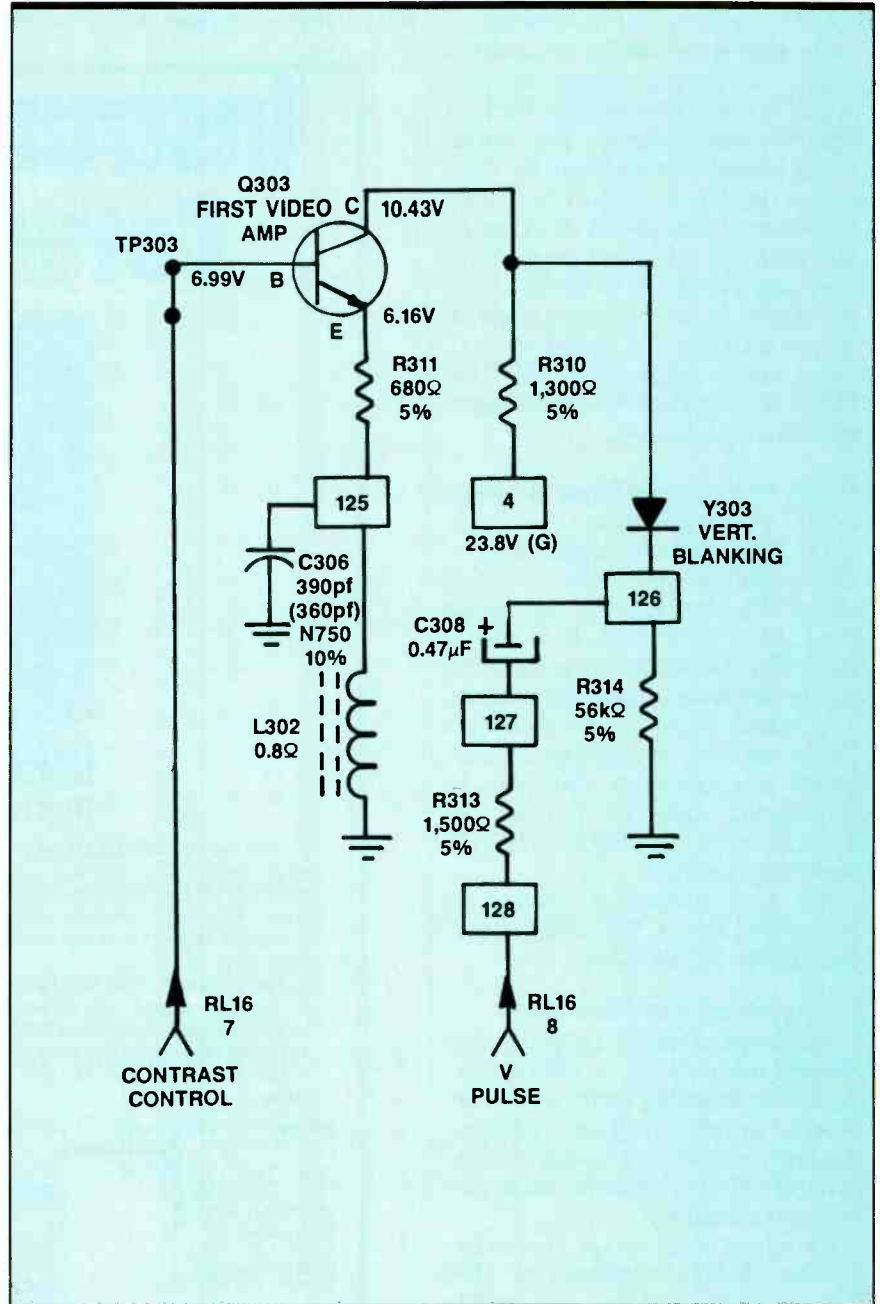

Figure 1. An incorrect replacement part caused a dark picture on the left side of this GE 25 MB's screen.

Answers to the quiz

Questions are on page 14.

1. Ambient.

Ambient temperature can be a limiting factor in the use of a component.

2. Bit.

The term is made from the words *binary digit*.

3. CET.

Certified Electronics Technician.

4. Efficiency.

When multiplied by 100, it is expressed as a percent value.

5. SCS.

Silicon controlled switch. Unlike an SCR that cannot be turned off by the gate, an SCS can be turned on and off by gate voltages.

6. Bridge.

When connected into opposite legs of a bridge, equal currents flow through the thermistor, so the heat dissipated by each thermistor is the

same. Only the ambient temperature of the thermistor used for measurement is a factor in the bridge balance.

7. Surge.

It is used to protect the diode during the charging period of filter capacitors.

8. UJT.

The intrinsic standoff ratio sets the value of emitter voltage (as a propor-

tion of the power supply voltage) required for turning the UJT on.

9. Byte.

Many microprocessors and digital circuits work with data delivered one byte (eight bits) at a time.

10. Data.

This type of flip-flop is used to store information in random access memories.

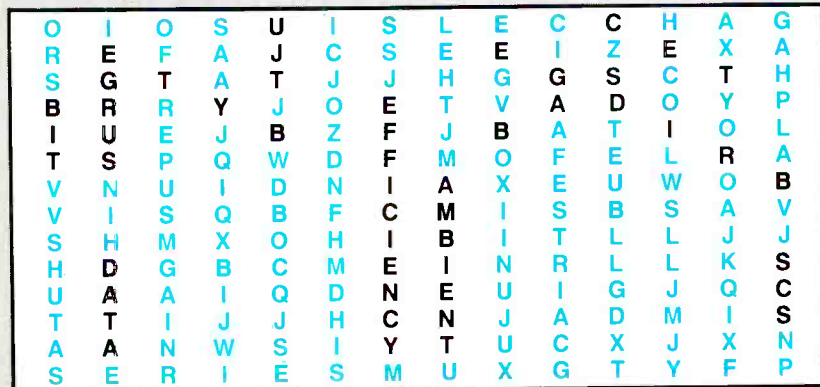

New for 1989...

MSC's Spring/Summer Training Materials Catalog ...and Special Introductory Offer!

The latest Training Materials Catalog from MSC features 19 pages of training aids for servicing video, audio, and telecommunications products computers and more. Send for your free copy today, and take 15% off your first order! Simply deduct 15% from the order subtotal (before shipping and tax if applicable) and return the coupon below. (No photocopies please.) If you already have the 1989 catalog, please feel free to take advantage of this special offer as well. Hurry! offer ends September 30, 1989. See the order form in the catalog for details.

- Troubleshooting Tips
- Reference Manuals
- Videotapes
- Programs



Please send my free copy of your latest Training Materials Catalog. In addition, take 15% off the price of my first order (before shipping & handling).

I already have a copy of the latest catalog, but would like to take advantage of this special offer anyway.

Name _____ Company _____

Address _____

City _____ State _____ Zip _____

Sale ends September 30, 1989. Please enclose this coupon with your order. Sorry, no photocopies will be accepted.

Matsushita Services Company

... Service is our middle name!

Matsushita Services Company TAS/Publications 2B-6
50 Meadowland Parkway Secaucus, N.J. 07094
Division of Matsushita Electric Corporation of America

Panasonic

Technics

Quasar

Circle (9) on Reply Card

Products

Vacuum case

Chicago Case is offering the model CDZVAC Vacuum/Pack, a Cordura case designed for carrying the 3M 496 Service Vac, the Atrix AAA Toner Vac and the Eltrex Laser Vac. The design fits piggyback-style vacuums with a separate, large compartment in the top of the bag for spare parts and accessories.

Circle (89) on Reply Card

Sweep/function generator

The model 3026 sweep/function generator from *B&K-Precision* is a 0.5Hz to 5MHz signal source with integral frequency counter. Features include internal or external AM modulation, variable dc offset internal or ex-

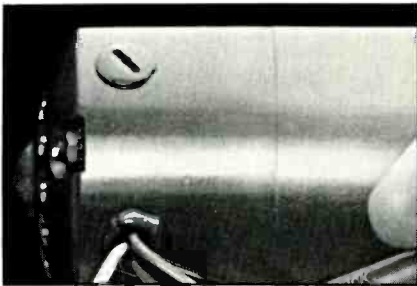

ternal gated burst operation, three calibrated steps and variable attenuators. The sweep generator functions offer variable sweep width and rate, plus a sweep ramp output for oscilloscope sync. A separate TTL output provides the correct output level without set-up adjustments.

Circle (90) on Rapid Facts Card

Digital multimeters

The SOAR models 3210, 3220 and 3230 digital multimeters from *Carlo Gavazzi Instruments* feature 3,200-count, full-scale analog bar graph displays, a 3½-digit readout, high sampling and LSI circuit technology that extends battery life. The hand-held multimeters incorporate manual and autoranging circuits, high-speed sampling for the 32-segment analog LCD display, and audible continuity and diode testing functions.

Circle (91) on Reply Card

Test signal generator

The TSG-100 from *Tektronix* is an 8-bit digital NTSC test signal generator that ensures conformance to RS-170A. It includes SMPTE color bars; a convergence pattern; multiburst; pulse and bar with window and modulate pulse;

a 5-step staircase; a modulated five step; white field and black burst. Features include a 1kHz audiotape and H or V rate scope trigger signal.

Circle (92) on Reply Card

Field kit

Jensen Tools' JTK-87 field engineer's kit has been modified to include a meter and oscilloscope. The JTK-87EK features the complete JTK-87 tool kit, which has more than 70 tools, a Fluke 88 DMM and a model 222 Tektronix oscilloscope. All are contained in a deep Rota-Tough case with gate-swing pallets. The wing pallet has a pocket to hold the meter, and foam dividers in the case bottom hold the scope. The kits can be customized according to the individual need with other available scope models or without a scope and meter.

Circle (93) on Reply Card

Digital multimeter

A.W. Sperry has introduced the model DM-400A, a 3½-digit, rotary-switch DMM. The pocket-size meter features overload protection, current reading, a ½-inch-digit, easy-to-read LCD, and 150 hour battery life. The DM-400A incorporates six functions on 19 ranges. These functions include dcV (0-200/2/20/200/1,000V), acV (0-200/700V), dcA (0-200μ/20m/200m/10A), ohm (0-200/2k/20k/200k/2M/20M), diode check (0-2kΩ) and continuity (0-200Ω).

Circle (94) on Reply Card

Dual time-base scope

The model 1041 40MHz, dual-trace, dual time-base oscilloscope from *Leader Instruments* features triggering controls such as variable hold-off; TV sync separators; high- and low-frequency rejection; and delayed, sweep-triggered functions. The scope has 1mV sensitivity and a channel 1 output available on the rear panel to drive other, less sensitive instruments.

Circle (95) on Reply Card

VCR lock

The Video Halt VCR lock and protector covers and locks the front loading door on VHS, Beta and 8mm VCRs to keep food, fingers and toys from being inserted into the player. The device's Lock in Play feature allows a videotape to be played while locked inside. This design gives parents the ability to lock out objectionable videos and lock in the

tapes of preferred viewing.

Circle (96) on Reply Card

Test clips

Pomona Electronics now packages the Grabber test clips in color assorted kits. Kit model 5522 contains 10 pieces of Pomona's do-it-yourself Minigrabber test clip, model 3925. A second kit, model 5523, contains 10 pieces of model 3781-24, a 24-inch patch cord with Minigrabber test clips on both ends. Each kit contains one of each of the 10 EIA colors. The Grabber test clips are designed to provide secure test point contact with a gold plated, spring-loaded hook.

Circle (97) on Reply Card

Test hook

E-Z Hook is offering a complete family of heavy-duty E-Z Macro Hook test probes, which include an insulation-piercing needle point model for testing large leads and cable. The test probes



come in a standard hook style (XH series) and insulation-piercing, needle-point-equipped hook configuration (XJ series). Both are available in more than 175 test-lead lengths and interfacing connector/plug assemblies.

Circle (98) on Rapid Facts Card

Dual display DMM

The Fluke 45 5-digit, 100,000-count DMM, available from *Contact East*, allows the user to measure two signal parameters from a single test connection and view both measurements at the same time. The DMM features measurement selection, dB measurements, audible continuity and diode tests, a touch-hold function that captures stable measurements, a relative mode that shows changes between readings, and a compare function for in-tolerance limits testing. Readouts show both hi/lo/pass evaluation and measured value.

Circle (99) on Reply Card

WORLD-CLASS ACCURACY & ECONOMY

Circuit board racks

Trace Racks circuit board racks can be used for storing, carrying and processing printed circuit boards. The GFR-4 protects ultra-sensitive MOS devices with an electrically conductive plastic material. The rack also provides resistance from most solvents and acids and withstands temperatures of 175°F. Two other models, the GFR-3 (polypropylene) and GF-2 (fiberglass-reinforced plastic for temperatures to 400°F), are also available.

Circle (100) on Reply Card

Thermal wire strippers

Patco wire strippers, available from *HMC*, are small, ac-line-operated tools that incorporate a nichrome element which heats up in less than 5s. The low mass, guarded element minimizes the risk of burns, eliminates nicks and broken strands of conductors, and reduces lead pull on sensitive components. Three basic models are available for stripping thermoplastic or high-temperature insulation and coaxial cable.

Circle (101) on Reply Card

Microwave oven protector

Philips ECG has introduced a surge suppressor designed to protect microwave ovens. The EMF-41M protects all three ac line modes (hot to neutral, neutral to ground, and hot to ground) against dangerous power surges. It features an RF noise filter and an indicator. It can also be used to provide surge protection for refrigerators, freezers, air conditioners, kitchen appliances, TV sets, VCRs and audio equipment.

Circle (102) on Reply Card

PC test cards

Global Specialties has announced the Proto-Card series of development and test aids for personal computers. The series consists of several development cards that plug into the bus of any IBM XT/AT compatible computer, allowing the user to construct and test circuits inside and outside the computer cabinet. The PB-88 series of cards provide access to the IBM (R) bus signals using Global's solderless interface sockets. The cards have a selection of breadboarding socket areas, which allows the construction of prototype or custom circuits. Many include address decoding.

Circle (103) on Reply Card

SOAR 3255

SOAR 3250



\$129⁹⁵ LIST



AT YOUR FINGERTIPS

3200 Count, Full Scale DMM With Analog Bar Graph Display, Sealed Case @ \$144⁹⁵ LIST

Count on our 3200 Series DMMs for feature-packed performance, LSI circuit reliability and accuracies up to .3%... with high speed auto ranging — up and down, 6 per sec. — data hold, and high speed sampling for the 3200 segment Analog Bar Graph. The model 3255 has a high impact ABS case that's waterproof (to JIS standards),

dustproof, shock and heat resistant. It offers temperature, continuity and diode test functions; ADP mode; and measures the standard AC/DC functions you expect from your DMM. The model 3250 offers the same capabilities and is packaged in an industrial-type, dustproof case. Both carry our 3 year warranty.

Now... Check These Additional Models For More DMM Values...



Model 3210
0.7% acc; DC LSI circuit; speed sampling; ADP mode; Analog Bar graph. \$69⁹⁵ LIST



Model 3220
0.5% acc; DC LSI circuit; speed sampling; auto/manual; ADP; Analog Bar graph. \$79⁹⁵ LIST



Model 3230
0.3% acc; DC LSI circuit; auto/manual; data hold; ADP; speed sampling; Analog Bar graph. \$94⁹⁵ LIST

Send For New 1989 Catalog

**CARLO GAVAZZI
Instruments**

CG Instruments Corp.

434 Windsor Park Drive, Dayton, OH 45459
Tel: (513) 434-6952 • FAX: 513-434-7643

Circle (35) on Reply Card

August 1989 *Electronic Servicing & Technology* 19

Servicing Zenith microcomputers

Part II: Introduction to the CPU

By John A. Ross

In Part I of this series (see "Servicing Zenith Microcomputers, Part I: The Backplane" in the June issue), we defined terms, traced signal paths and discussed the general operation of the Zenith Z-150 series microcomputer. We also talked about the layout and construction of the backplane and the interface between the various cards in the microcomputer. A thorough understanding of this circuitry provides a solid foundation for the logical analysis and troubleshooting of the computer. In this discussion of the central processing unit (CPU) card, those terms and signals defined in the backplane description become increasingly recognizable.

The brain of the system

An analogy serves to bring the purpose of the CPU card into a sharper focus for the technician. While the backplane acts as the interconnecting bloodstream of the microcomputer, the CPU works as the brain of the unit. The name given to the card — central processing unit — essentially describes its function. As the name implies, the CPU card processes information in the form

of data carried on the backplane. Containing an 8088 microprocessor, the CPU card handles decision-making and control functions for the microcomputer. Naturally, the microprocessor does not make decisions by itself. Instead, the CPU receives data from other sources and processes it according to prompts given by the microcomputer operator or peripheral devices.

In early models of the 150 series, Zenith used an integrated circuit similar to the famous NMOS Intel 8088 microprocessor IC: the CMOS Harris 80C88. Using the same instruction set and having nearly the same operating parameters as the Intel chip, this particular version of the microprocessor functions the same as the Intel 8088. Although computer-oriented technicians may see a familiar name in the 8088 nomenclature, they may not realize one primary difference between the original Intel IC and the Harris microprocessor. Aside from the difference in the NMOS vs. CMOS construction technologies, the Harris IC also requires an additional timing flip-flop for use during the interrupt request cycle. Because of a variety of system upgrades, Zenith shifted its use from the Harris microprocessor to the Intel 8088-2 microprocessor.

Versions of the IC

Operating at the user-selectable frequencies of 4.77MHz and 8MHz, the 8088-2 microprocessor can address more than a million data address locations and 64,000 input-output locations. As technology improved, the host CPU printed circuit card also changed. Figures 1 and 2 show the evolution of the card. Figure 1 shows the early version, often seen in the Z-151 models; Figure 2 illustrates the later version, seen in the A-158 and Z-159 microcomputers. The later version of the CPU card offers selectability between two clock frequencies. Technicians will find a pushbutton for that frequency selection on the rear mounting plate of the card above the keyboard connector.

Although early models in the 150 series require an additional card for the system random-access-memory (RAM) ICs, later versions feature a combination CPU/memory card. Combining the two functions onto one card became possible with the advent of gate array technology. Formerly requiring separate ICs, the circuitry for signal generation, direct memory access, parity generation and interrupt acknowledge functions lies within the gate array. Along with the additions of system RAM and frequency

Ross is a technical writer and a microcomputer consultant for Fort Hays State University, Hays, KS.

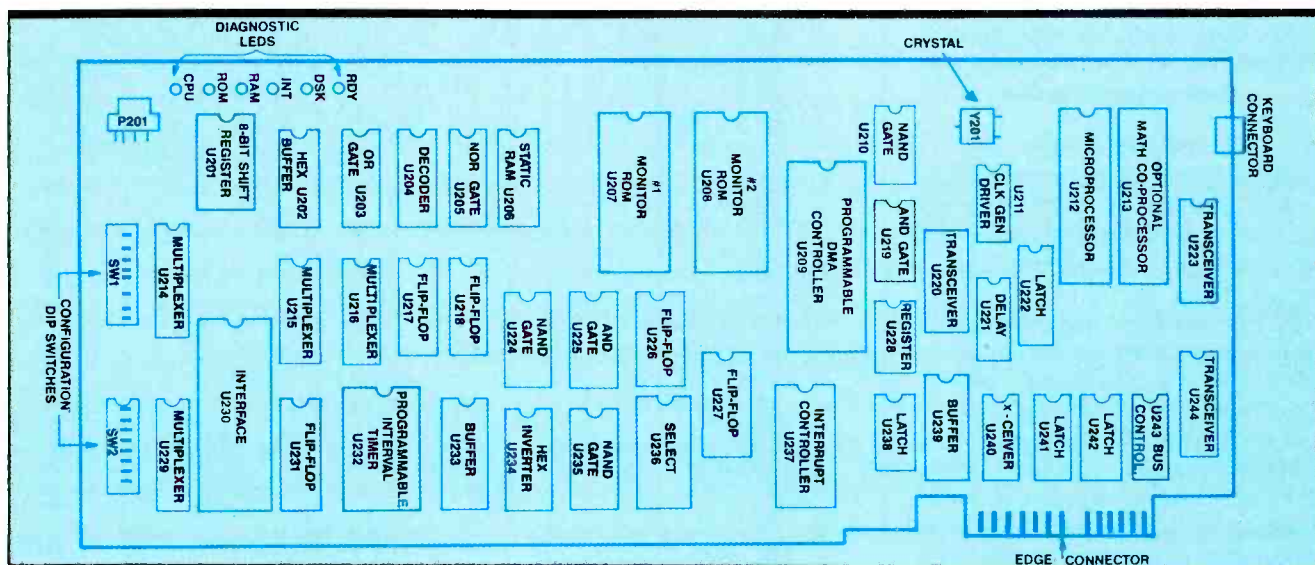

Figure 1. As technology improved, Zenith's host CPU printed circuit card also changed. This figure shows one variant of early production CPU cards, often seen in the Z-151 models.

selectability, the newer versions of the card also feature a parallel port connector for a peripheral device such as a printer.

Communication within the microprocessor

Three sections make up the internal workings of both microprocessor types. An arithmetic logic unit or ALU performs calculations. The control section of the IC keeps data, in the form of numeric-based machine language, flowing in the proper order. Also, the control section times the data so it reaches the proper destination in the required sequence. A small memory section in the microprocessor holds data for the ALU and control sections.

Communicating through three line buses, the 8088, located on the card, sends and receives instructions from the keyboard and peripheral devices. Machine-language program codes, stored either in the read-only or the random-access memories of the system, dictate the purpose of the instructions. Those instructions have noticeably differing forms:

- *Firmware*, stored in the ROM, has a permanent status with the microcomputer. Examples of firmware commands

range from programs for loading an operating system to preliminary test diagnostics. U207 and U208, the system ROMs, instruct the microprocessor on reading the keyboard and initializing the rest of the microcomputer system. When we progress to the system problem diagnosis, we'll take a closer look at the firmware.

- *Software*, stored in the RAM, has a temporary status. Examples of software stored in the RAM range from the operating system software such as MS-DOS to application packages such as word processing or database software.

As seen in the backplane description, three buses or groups of lines feed into the microprocessor chip. Figure 3, featuring a block diagram of the CPU card, gives an idea of the communication back and forth through the buses. Reviewing the backplane signal operation for a moment, a data bus, an address bus and a control bus connect the other devices with the CPU card. Lines A2 through A9 transfer eight bits of bi-directional data to the central processing unit.

As mentioned in Part I, Zenith employs a 16-bit microprocessor using eight lines for transferring the data. Twenty address lines found on the

backplane, A12 through A31, give the 8088 chip access to the memory address locations. The signals on the remaining lines of the signal bus work in sequence to determine the type of performed operation, such as memory read or write. Along with those signals, other signals in the same bus control the timing of the data exchange between the individual devices and the central processing unit.

Special precautions

Any time a technician will be working on a CPU circuit board, it is important to exercise care. The board contains electrostatic-sensitive devices. Working with these types of devices calls for good bench habits such as wearing a ground-strap bracelet, using an anti-static work mat and using test equipment and tools that have built-in allowances for ESD-sensitive devices. Technicians should also remember to transport the CPU card or any other printed circuit cards in anti-static shipping bags. Before removing the cards from the anti-static shipping bag, the technician should place one hand on the workbench top. If storing the cards in a cabinet or on the bench-top, technicians should again enclose the card in the anti-static ship-

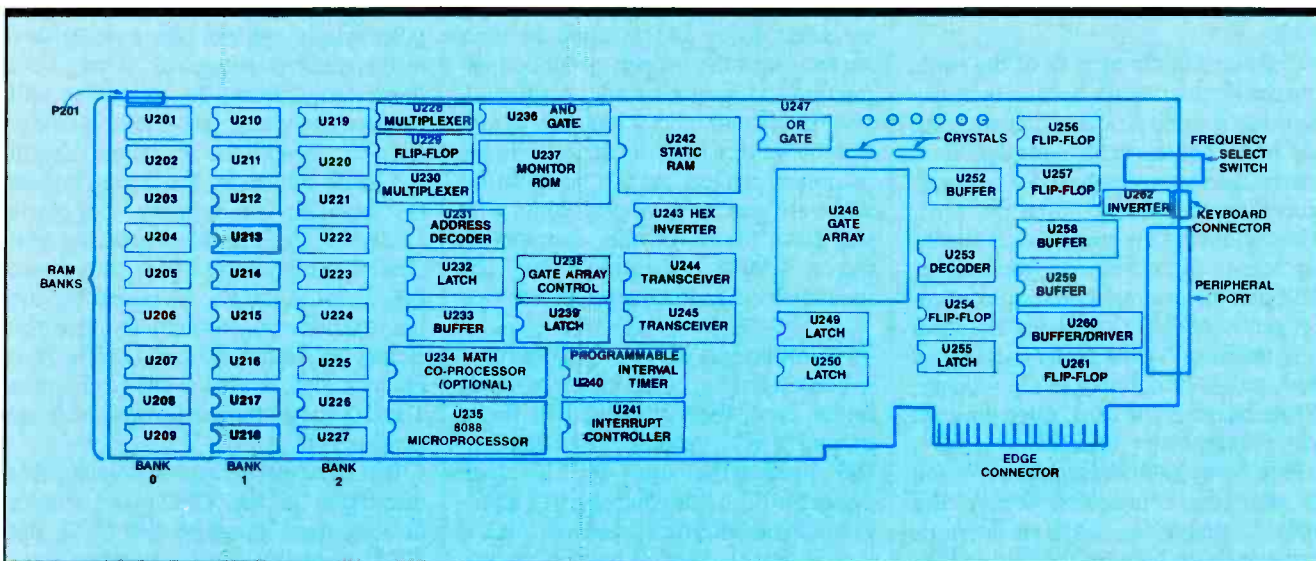

Figure 2. In this variant of later production CPU cards, often seen in the A-158 and Z-159 models, the CPU card offers selectability between two clock frequencies.

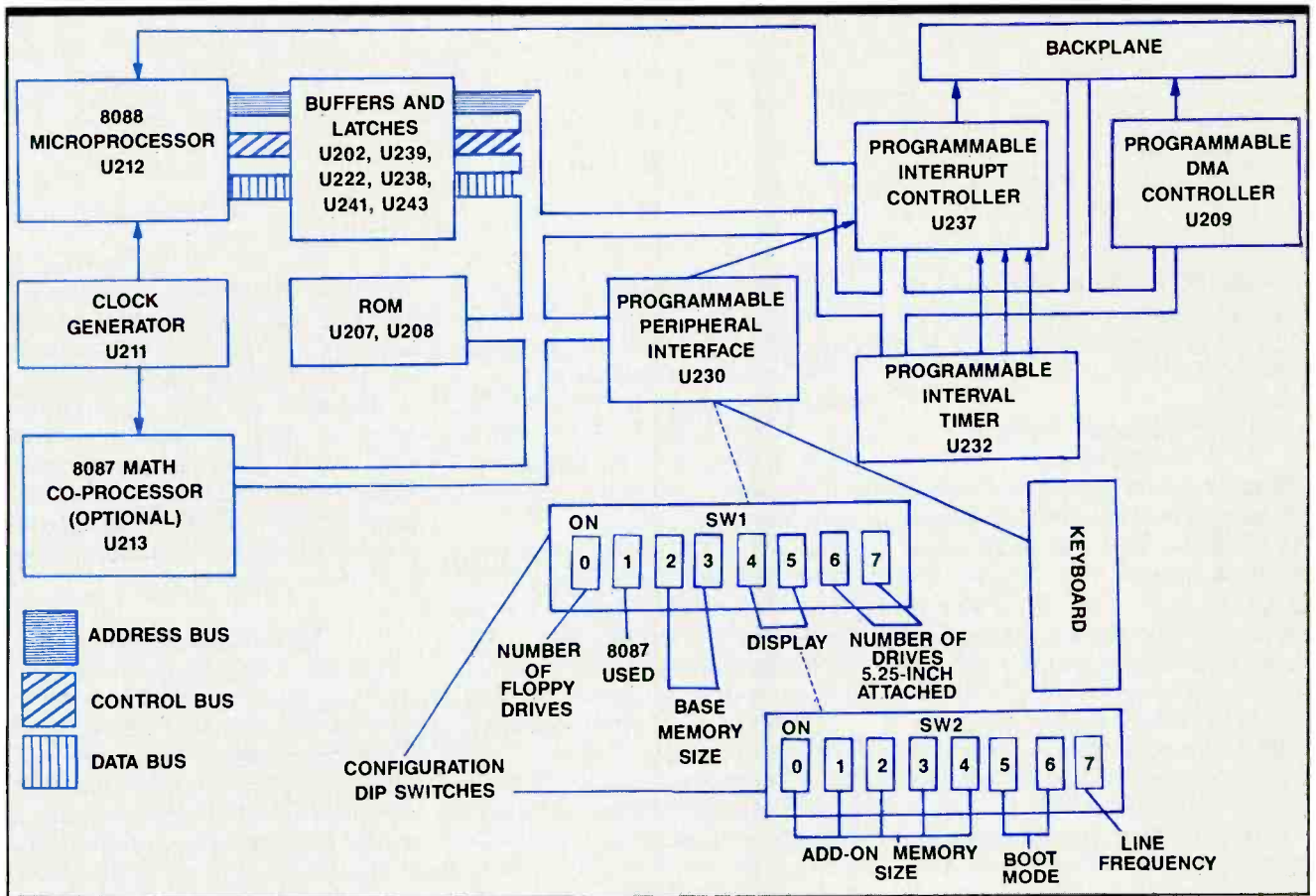

Figure 3. This block diagram of the signal flow in a typical CPU card gives an idea of the communication back and forth through the buses.

ping bags. Other necessary precautions also come to mind. Aside from the dangers of static damage, technicians should remember that all printed circuit cards in the Zenith microcomputers feature multilayer construction. Extreme heat, applied from the wrong type of soldering iron, can damage the card. Because of the very fine traces, technicians should minimize any flexing of the card.

Considering the tight fit of the cards into the Zenith chassis, technicians may experience some problems in extracting and replacing the card. Although flexing the card seems to work for removal, ignore the impulse to force the card. After removing the rear bracket fastening screw, the connector from socket P201 and the external keyboard connector, gently work the card back and forth in its retainers. While gently rocking the card, pull it straight out of the retainer. When inserting the card, align the card with its respective brackets.

Finally, technicians should not touch the card edge connectors. Greasy film from fingertips can cause an intermittent connection between the card and the backplane connectors. After servicing the card, wipe the edge connector with

a towelet to insure that the connector has a clean conducting surface.

While using good service procedures with the wide variety of cards found in microcomputers, technicians should also exercise care when dealing with the components mounted on the boards. Although some components have hard-soldered connections, others mount into sockets. The ICs should be carefully extracted from and inserted in their sockets with the proper, grounded extraction and insertion tools. A small investment in tools goes a long way to protect the service investment. As with the complete printed circuit card, follow anti-static practices when dealing with the ICs. Many of the components feature CMOS construction that calls for delicate handling procedures.

Components on the CPU card

Looking at the components mounted on the card, the technician will find a myriad of ICs, including the 8088 central processing unit IC, a clock generator IC, a bus controller IC, a programmable interrupt controller IC, a programmable interval timer IC, a programmable peripheral interface IC and its accompanying configuration switch-

es, read-only memory ICs, buffer and latch ICs and the direct memory-access controller IC. Some of these ICs disappear in the design evolution of the newer CPU card and its inherent combining of functions into one semiconductor.

All Zenith CPU cards in the 150 series microcomputers have a slot for an optional math co-processor IC. When we examine options for the microcomputer system, we will take a closer look at the math co-processor. Along with those components, the technician will also see five green light-emitting-diodes (LEDs). As with the backplane, Zenith has made life easier for the technician by including preliminary diagnostic LEDs on the central processing unit card. The diagnostic LEDs, along with the error messages supplied by the microprocessor, sequentially give the technician a quick idea of possible trouble locations. A glance back at Figures 1 and 2 shows the positioning of these components.

Part III of this series will continue this discussion of the CPU card with a detailed description of how U212, the 8088 microprocessor, communicates with and controls other portions of the microcomputer system. ■

EVERY SONY PRODUCT COMES FULLY EQUIPPED WITH OUR DEDICATION TO QUALITY SERVICE.

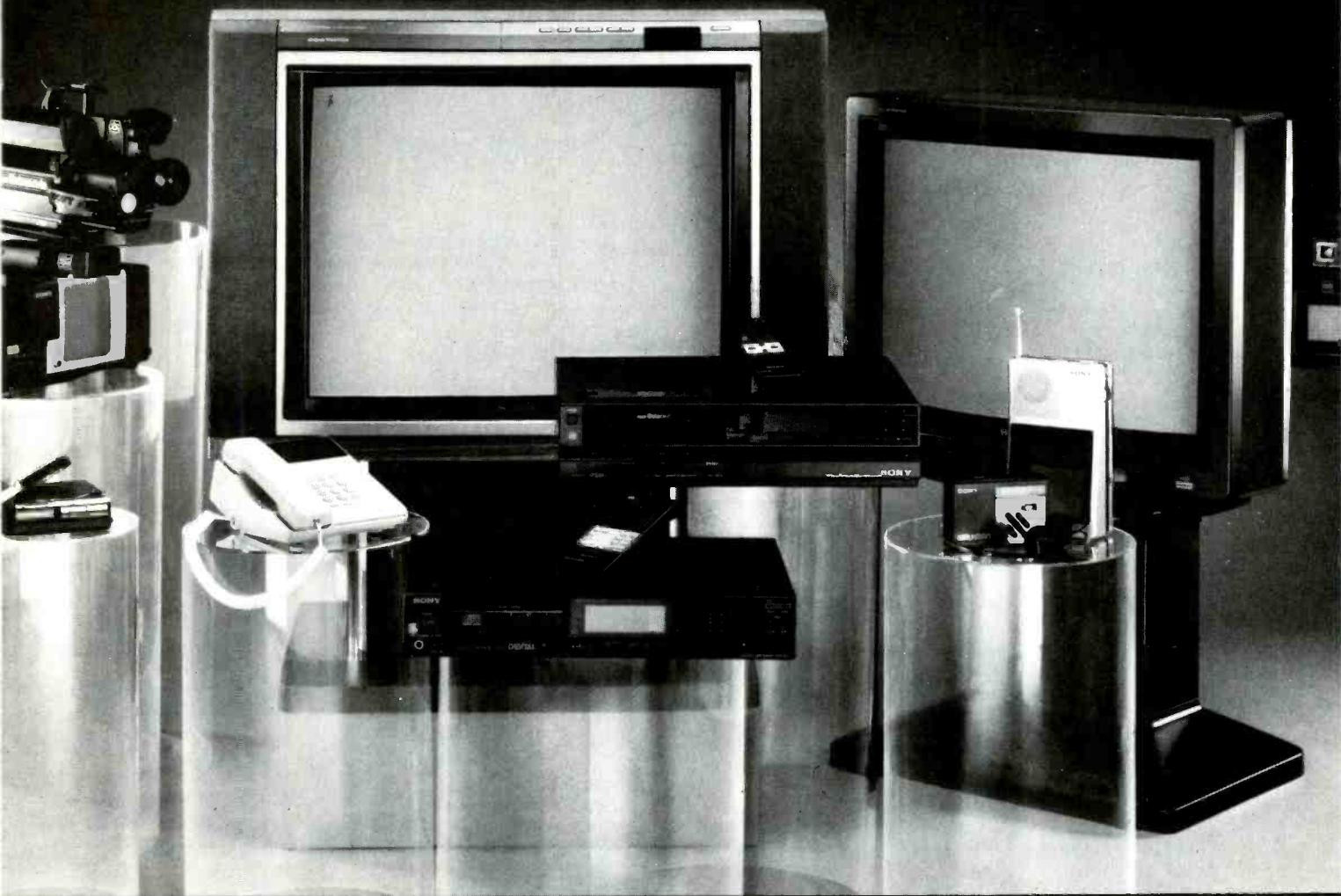

Your customers may never need The Sony Service Company, but it's comforting to know we're only a phone call away.

Our nationwide network of Sony Service Centers, Training and Technical Departments and our National Parts Center represent our commitment to service. This means if you sell or service Sony products, Sony is there for you. Read on to find out more.

1. Sony Service Centers. Repair work is performed at over 27 Sony Service Centers located throughout the country (even Hawaii). The Centers also sell Sony accessories and rent video equipment. For the nearest Sony Service Center call (201) 930-SONY (7669).

2. Regional Centers. Our Regional Centers are set up to assist you with any technical questions. Just call one of the following numbers. Mahwah, NJ (201) 529-1616; Philadelphia, PA (215) 632-7999; Irving, TX (214) 550-5269; Fort Lauderdale, FL (305) 920-5656; Honolulu, HA (808) 834-6622; Niles, IL (312) 647-2424; Detroit, MI (313) 477-4805; Costa Mesa, CA (714) 549-4836, San Jose, CA (408) 280-7675.

3. Training & Technical Departments. Because constant innovation is the rule in the field of consumer

electronics, authorized servicers and Sony Service Center technicians need the latest information available. This information is provided through training sessions at our Regional Training facilities and publication of Service Bulletins by our Technical Department.

4. National Parts Centers. All Sony Service Centers, parts distributors and authorized servicers depend on the National Parts Center. The Center also provides up-to-date service manuals and training tapes. To receive the Comprehensive Service Literature brochure free of charge write: Sony Service Company, National Parts Center, 8281 NW 107th Terrace, Kansas City, MO 64153 Attention Publications Department or call (816) 891-7550.

SONY®

Sony Service Company

A Division of Sony Corporation of America

RCA CTC120
Photofact 2217-1

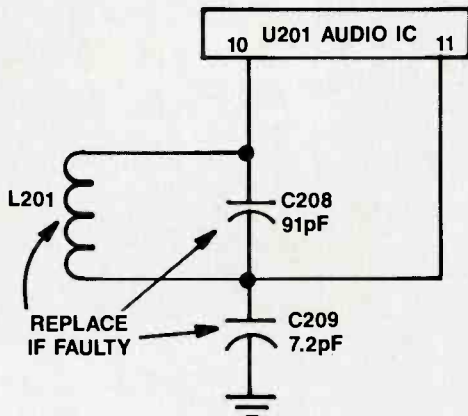

Symptom: Distorted and weak sound.
Cure: Replace C208, C209 and L201. Adjust L201 for best sound.

RCA CTC120
Photofact 2217-1

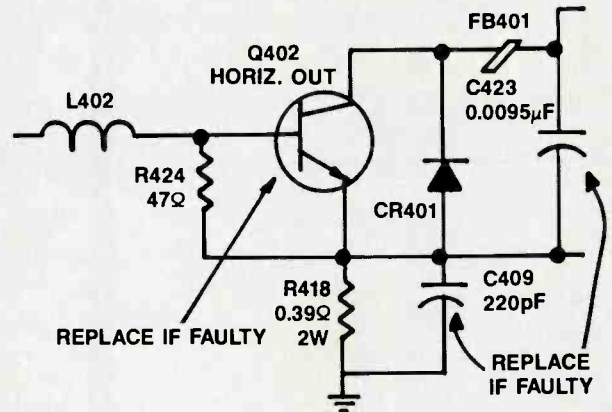

Symptom: Repeated failure of Q402.
Cure: Replace C423, C409 and Q402. Test for normal voltages and waveforms.

RCA CTC120
Photofact 2217-1

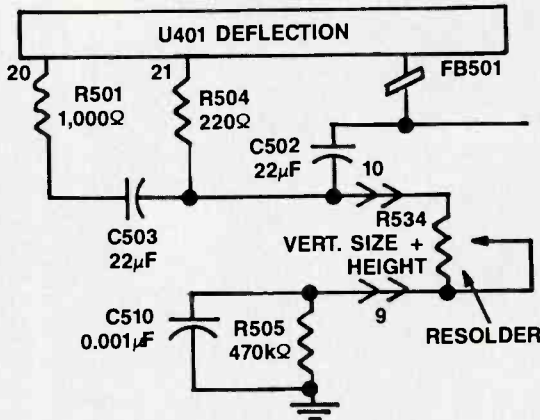

Symptom: Intermittent vertical collapse.
Cure: Resolder connections on the vertical height control.

RCA CTC110
Photofact 2033-2

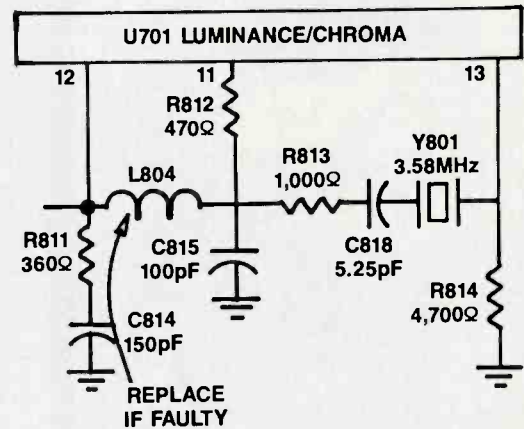

Symptom: No color.
Cure: Replace L804, a 27μH inductor, and adjust chroma level.

RCA CTC120
Photofact 2217-1

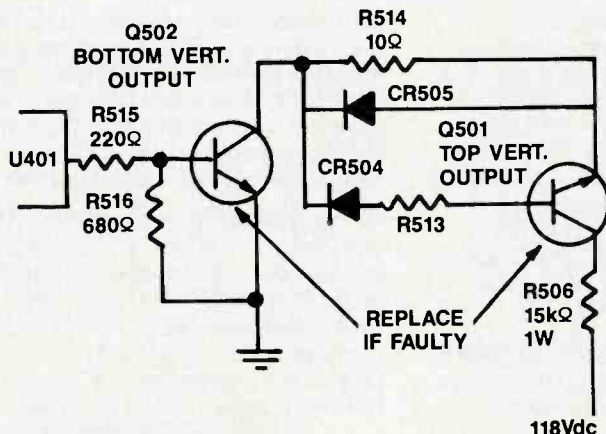

Symptom: Intermittent vertical collapse or poor height and linearity.
Cure: Replace Q501 and Q502 vertical output transistors.

RCA CTC110
Photofact 2033-2

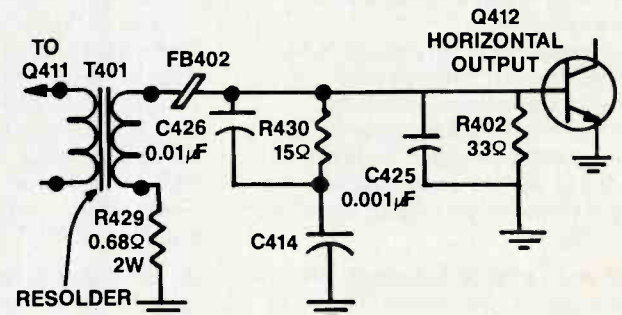

Symptom: Dead set with "tic-tic" sound.
Cure: Resolder connections on T401 driver transformer.



REPLACEMENT PARTS SHOWCASE

Choosing your replacement parts supplier

After you've pinned down the diagnosis of a TV, VCR or stereo system, and you've isolated the problem to the component level, you might think the tough part is done. However, then comes the job of finding a replacement part. Sometimes it's easy — just go to the parts storage and grab it off the shelf. Sometimes it's a little harder — you have to call the distributor or even the manufacturer and work with the parts specialist until you're sure you have the correct item. Sometimes it's nearly impossible — the TV, or whatever, is a no-name.

Why all this fuss?

Finding elusive replacement parts is one of the most difficult and frustrating tasks encountered by servicing technicians. Today there are thousands of transistors and ICs, many of them specially made parts for which there is no equivalent. Other parts (transistors, for example) may be general purpose, but every manufacturer has its own numbering system. If there's no generic number on the device, or cross reference, the part may as well not exist.

The reputable manufacturers and distributors share the frustration of servicing technicians. The manufacturers

want technicians to fix the products bought by their customers. Of course, every time they sell a replacement part, they make a profit. Distributors also want to sell replacement parts with a minimum of fuss. That's why they're in business. So if it sometimes seems that these organizations are being uncooperative just for the sheer perversity of it, you can be assured that that's not the case. They're trying just as hard as they can to make it easy to identify and order replacement parts.

May we introduce...

The advertisers who are represented in this special advertising supplement have taken this opportunity to tell you a little more about themselves than they ordinarily can in just an ad. They want technicians to be aware of what kind of facilities they have, what kinds of people work for the company, the efforts they are making to keep the satisfaction of their customers — you — as high as possible, and how to contact them when you need a replacement component.

Here are some of the questions we asked the manufacturers and distributors to address in their articles:

- How many locations do they have?
- How often do they fill orders from

materials in stock?

- What payment options do they offer — open order account, credit card?
- How soon after receiving the order do they ship?
- Do they add a shipping surcharge?
- Do they have toll-free numbers?
- What ordering options do they offer?
- What is their return policy?
- Do they offer a warranty?
- Is there a minimum order amount?
- What shipping options do they offer?
- What special services do they offer?
- Do they have a research department to locate specific parts?

When you're searching for a replacement part supplier you can count on for convenience and service, keep some of these questions in mind. After all, just finding someone who carries the part isn't the only consideration. If you have to wait until you fill a minimum order amount before you can order or if you have to wait weeks for the part to arrive, you're stuck with a defective TV and, probably, an irate customer. The impulse to order from the first name in the phone book might be great, but take the time to ask some questions. It could save time, money and aggravation. The following section will give you a head start in answering some those questions.



REPLACEMENT PARTS SHOWCASE

Joseph Electronics

8830 N. Milwaukee Ave., Dept. K
Niles, IL 60648
800-323-5925; FAX: 312-297-6923

FREE TEST EQUIPMENT. That's what the headline in the ad below says and that's exactly what Joseph Electronics is offering. It's remarkable and it's true.

But this current promotion is only the latest in a series of money-saving offers from Joseph Electronics.

Joseph Electronics has always concentrated on superior service at competitive pricing. The company has been providing customers with the best of both. And now it is doing even more. Along with competitive factory-direct pricing, Joseph Electronics has developed this special promotion. Now, for a limited time, Joseph customers who use Sony, Panasonic, Technics and Quasar replacement parts can actually get top-of-the-line test equipment FREE!

For more than 40 years, electronics technicians all over the country have counted on Joseph Electronics for prompt and courteous service. They

have had access to genuine factory replacement parts at factory-direct prices for the latest consumer electronics devices: TVs, VCRs, camcorders, CD players, audio recorders and much more. Appliance, office machine and even FAX parts are also in stock — thousands of genuine factory parts from the computerized Joseph inventory, all available for immediate delivery. All backed by full factory warranties.

Customers place their orders with confidence, knowing that Joseph will provide fast, reliable delivery with orders shipped the same day they are received. And electronics technicians everywhere know they can count on free technical and parts selection assistance from experienced, professional, real-life people any time they call, write or FAX Joseph Electronics.

Use the company's toll-free number, 800-323-5925, or its FAX, 312-297-6923, and start saving your test equipment dis-

count certificates. You could get your next piece of test equipment FREE!

Yes, variety, range, service and depth of parts coverage help define Joseph Electronics as an industry leader. That leadership is accurately reflected in the more than 130 product lines carried in stock and proudly displayed in the 528-page Joseph Electronics catalog. It's easy to get your own copy FREE. Just send a request on your company letterhead or add one to your next order and the latest edition will be on its way.



SPECIAL ADVERTISING SUPPLEMENT

FREE Top-Name Test Equipment

• ARI-American Reliance • B&K • Beckman • Fluke • Goldstar
• Hitachi • Kenwood • Leader • Simpson • Tektronix



Buy Sony, Panasonic, Quasar, and Technics exact original replacement parts from Joseph Electronics between now and November 30, 1989, and get discount certificates for the test equipment brands featured.

USE THESE SPECIAL CERTIFICATES
TO GET DISCOUNTS UP TO 100%
—THAT CAN MEAN FREE TEST EQUIPMENT!

With each \$100.00 worth of SONY, Panasonic, Quasar, and Technics parts purchased at suggested dealer prices between now and November 30, 1989, Joseph Electronics will give you a \$10.00 Test Equipment Discount Certificate.

For example, your next parts order of \$500 gets you \$50 in Test Equipment Certificates—that you can use to buy a \$75 digital multimeter for only \$25.00! The more you order, the more you save!

And as an extra added bonus, shipping is FREE for parts orders of \$250 or more that are UPS shippable!

BE CERTAIN with EXACT Original Factory Replacement Parts for SONY • PANASONIC Technics • Quasar

From one of the largest AUTHORIZED parts distributors
JOSEPH ELECTRONICS, Inc. serving you since 1947

- All Parts Backed by Full Factory Warranty.
- Giant Computerized Inventory of Thousands of GENUINE Factory Parts Always on Hand.
- Quality Products for the Video/Audio Industry.
- Fast Reliable Delivery; Orders shipped Same Day Received.
- Free Technical Assistance for Correct Parts Selection
- Personal, Efficient, Experienced Sales Staff.
- Place Your Orders... Toll Free for Off-The-Shelf Delivery.

ORDER your EXACT REPLACEMENT PANASONIC and SONY PARTS
from JOSEPH ELECTRONICS and join our thousands of satisfied customers.



Call TOLL FREE
800-323-5925

Call today... place your order
and start collecting your valuable
discount certificates.

Write or Fax

Joseph ELECTRONICS

8830 N. Milwaukee Avenue, Dept. K • Niles, IL 60648
(312) 297-4200 • FAX: (312) 297-6923

Circle (12) on Reply Card

MAT Electronics

975 Jaymore Road
Southampton, PA 18966
800-628-1118; FAX: 215-364-8554

REPLACEMENT PARTS SHOWCASE

MAT Electronics is a full-line parts distributor that gears its inventory to the TV, VCR and stereo repair industry. The company's parts are used by technicians, engineers, trade schools, hobbyists and manufacturers.

MAT Electronics stocks an extensive line of replacement accessories as well as one of the largest selections of semiconductors in the nation.

The company publishes an easy-to-read, 32-page catalog with thousands of items, all inventoried in the company's computer, enabling customers to check availability within seconds.

With its huge overseas imports, as well as domestic sources for components, the company is always current with the industry — always emphasizing what is new in electronics components — for VCRs, TVs and stereos.

MAT Electronics takes great pride in its exceptional conscientious ability to

accommodate the varied needs of all of its customers. The company normally ships within 24 hours of your order; however, they offer UPS red and blue labels to ensure even faster delivery service if it is needed.

The company has friendly and knowledgeable telephone operators waiting to take your phone call and courteously deal with any questions you may have about any electronic part — even if you don't see it in the catalog, ask for it!

At MAT Electronics, they know that there are certain risks involved in mail-ordering certain components, and that is why the company guarantees 100% of all products for 90 days from purchase date. Volume discounts are always available. The company's toll-free lines are open now and waiting for your phone call. Just call 800-628-1118.

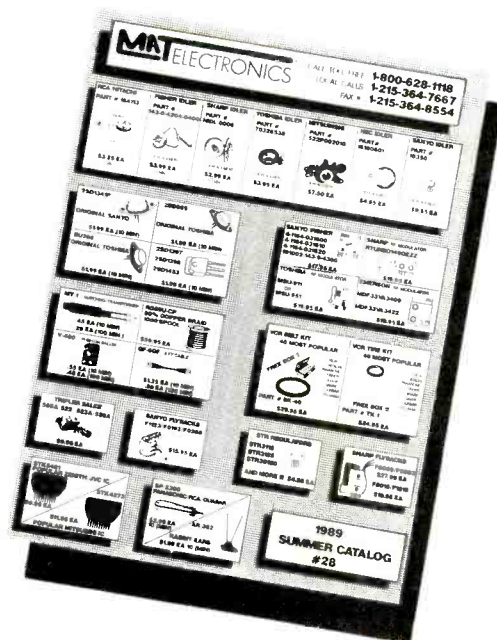

SPECIAL ADVERTISING SUPPLEMENT

POPULAR SEMICONDUCTORS

2SD1341P	Original Sanyo	10 For \$19.90
2SD869	Original Toshiba	10 For 19.90
BU208A	Original Toshiba	10 For 19.90
2SD1398	Original Sanyo	10 For 19.90
STR3115	Original Sanken	3.95 Ea.
STR3125	Original Sanken	3.95 Ea.
STR30120	Original Sanken	3.95 Ea.
STK4273	Original Sanken	(10 min.) 9.95 Ea.
STK0080	Original Sanken	15.95 Ea.
375 Replacement		(10 min.) 99¢ Ea.



VCR PARTS

SANYO RF Modulator #4-1164-031600	\$17.95 Ea.
FISHER RF Modulator 191002-143-9-4300	17.95 Ea.
MITSUBISHI RF Modulator #PU57855-01	19.95 Ea.
TOSHIBA RF Modulator #MSU-911	19.95 Ea.
RCA Loading Belt 157061 or 157062	10/For 8.50
FISHER Loading Belt 143-2-7504-01000	10/For 8.50
GOLDSTAR Samsung Photo Interrupter	1.99 Ea.
RCA Idler 164113	3.25 Ea.
FISHER Idler 143-0-4204-00400	3.99 Ea.
SHARP Idler NIDL0005	2.99 Ea.
SHARP Idler NIDL0006	2.99 Ea.



POPULAR ITEMS

Sharp Flyback	FO009G	\$27.95 Ea.
Sharp Flyback	FO003G	27.95 Ea.
Sanyo Flyback	FO260	14.95 Ea.
Sanyo Flyback	FO192	14.95 Ea.
Tripler	523A/526A	9.95 Ea.
Sanyo Focus Divider	Z0064	11.95 Ea.
Minus-62	Freeze Spray	4.95 Ea.
Freon TF Clnr./Precision Clnr. Degreaser		4.95 Ea.
Chemtronics Solder—1 Lb. Spool .031 Dia.		7.95 Lb.
Chem-Wick Lite	1/8 Dia. 25' Spool	5.50

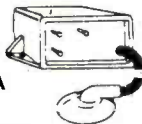

POPULAR CAPACITORS

100MFD/50 Volts	Radial	20 For \$10.00
4.7MFD/250 Volts	Radial	10 For 5.50
10MFD/350 Volts	Radial	10 For 7.50
1000MFD/200 Volts	Snap-In	5 For 12.50
680MFD/200 Volts	Snap-In	5 For 12.50
100MFD/200 Volts	Radial	10 For 12.50
47MFD/50 Volts	Radial	10 For 4.50
10MFD/25 Volts	Non Polarized	10 For 5.00
MFD/250 Volts	Snap-In	3.95 Ea.



ASK FOR OUR
FREE CATALOG!!!

CALL TOLL FREE: 1-800-628-1118

FAX #: 1-215-364-8554

MATELECTRONICS®

975 Jaymor Rd.

Southampton, PA 18966

Circle (13) on Reply Card

DELIVERY IS THE MOST IMPORTANT FUNCTION OF A PARTS DISTRIBUTOR. BUT IT'S NOT ENOUGH.

AVAILABILITY
DELIVERY
RELIABILITY
SUPPORT
NETWORKING
QUALITY

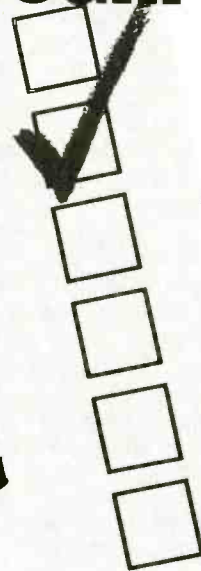

MATSUSHITA AUTHORIZED PARTS-LINK™ DISTRIBUTORS. BECAUSE IT PAYS TO BE SURE.

Some distributors are quick to promise fast delivery of replacement electronic parts. But they may not always be the right parts. That's never a problem when you put your trust in a Matsushita Authorized PARTS-LINK™ Distributor — your best source for Panasonic, Technics and Quasar original replacement parts. For basic stocking, each distributor maintains over 1,000 of the most demanded part numbers for off-the-shelf delivery. Even if the part you need isn't so common, your Matsushita distributor is tied into our exclusive PARTS-LINK™ network, tracking over 385,000 part numbers, so that we can locate the part you need, lock in the order, and deliver it — if overnight delivery is requested to your doorstep within 24 hours. They can even cross-reference these original

replacement parts to other Matsushita built products so that you can retain the high quality and reliability of Matsushita's design.

THE DIFFERENCE BETWEEN A PROMISE KEPT, AND A PROMISE BROKEN.

Your Matsushita Authorized PARTS-LINK™ Distributor isn't authorized by accident; each has met (and continues to meet) stringent requirements to ensure fast, courteous and responsive service backed by Matsushita's replacement parts warranty.

The right part at the right time from the right source. For the name and location of your Matsushita Authorized PARTS-LINK™ Distributor — see our listings at right. **YOUR SOURCE OF CONFIDENCE.**



MATSUSHITA SERVICES COMPANY

50 Meadowland Parkway, Secaucus, NJ 07094

Panasonic Technics Quasar

MATSUSHITA

AUTHORIZED REPLACEMENT PARTS DISTRIBUTORS

Panasonic® • Technics® • Quasar®

ARIZONA

ARIZONA WHOLESALE SUPPLY CO. (C/M) • 2020 E. University Dr., Phoenix 85062 • 602-258-7901
ELECTRONIC PARTS CO. (C/V/M) • 4021 N. 31st Ave., Phoenix 85017 • 602-227-7281

CALIFORNIA

ANDREWS ELECTRONICS (C/V/M) • 25158 Avenue Stanford, Valencia 91355 • 805-257-7700
AUDIO VIDEO PARTS, INC. (C/V/M/A) • 1071 South La Brea Ave., Los Angeles 90019 • 213-933-8141
CASS ELECTRONICS (C/V/M/A) • 801 Seventh Ave., Oakland 94606 • 415-839-2277
CHUCK HURLEY ELECTRONICS (C/M/A) • 2557 Albatross Way, Sacramento 95815 • 916-927-5891
E AND K PARTS, INC. (C/V/M/A) • 2115 Westwood Blvd., Los Angeles 90025 • 213-475-6848
HURLEY ELECTRONICS (C/M) • 10712 Inglewood Ave., Inglewood 90304 • 800-356-8734
HURLEY ELECTRONICS (C/M) • 739 W. Spruce, San Bernardino 92410 • 714-885-0721
HURLEY ELECTRONICS (C/V/M) • 318 16th St., San Diego 92101 • 619-235-6245
HURLEY ELECTRONICS (C/M) • 2101 N. Fairview, Santa Ana 92706 • 714-971-2992
PACIFIC COAST PARTS (C/V/M/A) • 15024 Staff Court, Gardena 92048 • 213-515-0207
WHOLESALE VACUUM (V) • 5811 Rose Ave., Long Beach 90813 • 213-428-6411

COLORADO

DENVER-WALKER ELECTRONICS (C/M) • 299 Bryant St., Denver 80219 • 303-935-2401

CONNECTICUT

SIGNAL ELECTRONICS SUPPLY, INC. (C/M/A) • 589 New Park Ave., West Hartford 06110 • 203-233-8551

FLORIDA

HERMAN ELECTRONICS (C/V/M/A) • 1365 N.W. 23rd St., Miami 33142 • 305-634-6591
LAYCO, INC. (C/V/M) • 501 South Main St., Crestview 32536 • 904-682-0321
VANCE BALDWIN (C/A) • 2207 S. Andrews Ave., Fort Lauderdale 33316 • 305-523-3461
VANCE BALDWIN (C/M/A) • 11629 N.W. 7th Ave., Miami 33168 • 305-769-0225
VANCE BALDWIN (C/V/M/A) • 1007 N. Himes Ave., Tampa 33607 • 813-870-2606
VANCE BALDWIN (C/V/M) • 500 Clematis St., West Palm Beach 33401 • 407-832-5671
WALDER ELECTRONICS (C/V/M) • 1801 N.E. 2nd Ave., Miami 33132 • 305-379-4794

GEORGIA

BUCKEYE VACUUM CLEANER (V) • 2870 Plant Atkinson Rd., Smyrna 30080 • 404-351-7300
WHOLESALE INDUSTRIAL (C/M/A) • 5925 Peachtree Corners East, Norcross 30071 • 404-447-8436

HAWAII

PANASONIC HAWAII, INC. (C/V/M) • 91-238 Kauhū St., Ewa Beach 96808-0774 • 808-682-2851

ILLINOIS

B & W, INC. (C/V/M) • 2137 S. Euclid Ave., Berwyn 60402 • 312-242-1533
HESCO, INC. (V) • 6633 North Milwaukee Ave., Niles 60648 • 312-647-6700
JOSEPH ELECTRONICS, INC. (C/M/A) • 8830 N. Milwaukee Ave., Niles 60648 • 312-297-4200
UNION ELECTRONIC DIST. (C/V/M/A) • 16012 S. Cottage Grove, South Holland 60473 • 312-333-4100
YEOMANS DISTRIBUTING CO. (C/V/M) • 1503 W. Altorfer Dr., Peoria 61614 • 309-691-0050

INDIANA

ELECTRONIC SERVICE PARTS (C/V/M) • 2901 E. Washington St., Indianapolis 46201 • 317-269-1527

IOWA

JONES DISTRIBUTING CO. (C/V/M/A) • 2650 Bridgeport Dr., Sioux City 51102 • 712-277-8600
YEOMANS DISTRIBUTING CO. (C/M) • 616 New York St., Des Moines 50313 • 515-280-8179

KANSAS

G & A DISTRIBUTORS, INC. (C/V/M/A) • 635 N. Hydraulic St., Wichita 67201 • 316-262-3707

KENTUCKY

MAJOR DISTRIBUTING COMPANY (C/M) • 449 S. 16th St., Paducah 42001 • 502-443-5345
SERVICE ELECTRONICS SUPPLY (C) • 1046A New Circle Rd., NE, Lexington 40505 • 606-254-5786

MARYLAND

FAIRWAY ELECTRONICS (C/V/M) • 3040 Waterview Drive, Baltimore 21230 • 301-576-8555
FAIRWAY ELECTRONICS (C/V/M/A) • 4210 Howard Ave., Kensington 20795 • 301-564-1440
TRITRONICS, INC. (C/V/M/A) • 1306 Continental Dr., Abingdon 21009-2334 • 301-676-7300

MASSACHUSETTS

MIL ELECTRONICS (C/V/M/A) • 27-33 Jones Rd., Waltham 02154 • 617-891-6730
SIGNAL ELECTRONICS SUPPLY, INC. (C) • 484 Worthington St., Springfield 01105 • 413-739-3893
TEE VEE SUPPLY CO. (C/V/M/A) • 407 R Mystic Avenue, P.O. Box 649, Medford, MA 02155 • 617-395-9440

MICHIGAN

G.M. POPKEY CO. (C/V/M/A) • 4477 East Paris Ave., S.E., Grand Rapids 49508 • 616-698-2390
REMCOR ELECTRONICS (C/M/A) • 10670 Nine Mile Rd., Oak Park 48237 • 313-541-5666

MINNESOTA

NESS ELECTRONICS, INC. (C/V/M/A) • 441 Stinson Blvd. NE, Minneapolis 55413 • 612-623-9505
MID AMERICA VACUUM CLEANER SUPPLY CO. (V) • 666 University Ave., St. Paul 55104 • 612-222-0763

MISSISSIPPI

TRI-STATE ELECTRONICS (C/V/M) • 605 W. Fortification St., Jackson 39203 • 601-355-3431

MISSOURI

CITITRONIX, INC. (C/V/M/A) • 1641 Dielman Rd., St. Louis 63132 • 314-427-3420
MANHATTAN ELECTRONICS, INC. (C/V/M) • 1101C E. 76th Terrace, Kansas City 64131 • 816-361-9440
TACONY CORP. (V) • 1760 Gilsinn Lane, Fenton 63036 • 314-349-3000

NEW HAMPSHIRE

TEE-VEE SUPPLY CO. (C/V/M/A) • 58 Elm St., Nashua 03060 • 603-889-4171

NEW JERSEY

NIDISCO ELECTRONICS (C/V/M/A) • 181 Route 46 W, Lodi 07644 • 201-773-1771

NEW YORK

DALE ELECTRONICS (C/V/M/A) • 7 E. 20th St., New York City 10003 • 212-475-1124
GREEN TELE-RADIO DIST. (C/M/A) • 84-00 73rd Avenue, Glendale 11385 • 718-821-1114
GMB SALES (C/V/M/A) • 140 Terminal Rd., Setauket 11733 • 516-689-3400
MILL ELECTRONIC SUPPLY (C/V/M/A) • 2026 McDonald Ave., Brooklyn 11223 • 718-336-4575
PAGO APPLIANCE PARTS (C/M/A) • 700 Broadway, Buffalo 14212 • 716-856-8133
PANSON ELECTRONICS (C/V/M/A) • 268 Norman Avenue, Greenpoint 11222 • 718-383-3400
RADIO EQUIPMENT CORP. (C/A) • 196 Vulcan St., Buffalo 14207 • 716-874-2690
STAR FOR PARTS (V) • 250 Rabro Drive East, Hauppauge 11788-0255 • 800-525-6046
UNITED TELETRONIC PARTS (C/M) • 3860 10th Ave., New York 10034 • 212-LO9-2330

NORTH DAKOTA

WESTECH DISTRIBUTING (C/V) • 1345 Main Ave., Fargo 58103 • 701-237-4885

OHIO

FOX INTERNATIONAL, INC. (C/V/M/A) • 23600 Aurora Rd., Bedford Heights 44146 • 216-439-8500

OREGON

DIVERSIFIED PARTS (C/V/M/A) • 2104 S.E. 9th Ave., Portland 97214 • 503-236-6140
THE MOORE CO. (C/V/M) • 333 SE 2nd, Portland 97214 • 503-234-5000

PENNSYLVANIA

AMERICAN VAC DISTRIBUTORS (V) • 3130 E. Thompson St., Philadelphia 19134 • 215-423-4522
CRS ELECTRONICS (C/M) • 818 Brownsville Rd., Pittsburgh 15210 • 412-431-7700
LINWOOD WHOLESALE, INC. (C/M) • 1139 Summer Ave., Whitehall 18052 • 215-820-0357
STEINBERG ELECTRONICS (C/V/M/A) • 2520 N. Broad St., Philadelphia 19132 • 215-BA3-9400

RHODE ISLAND

JABBOUR ELECTRONICS (C/V/M/A) • 1744 Cranston St., Cranston 02920 • 401-944-2570

SOUTH CAROLINA

WHOLESALE INDUSTRIAL (C/V/M) • 515 E. Bay St., Charleston 29403 • 803-722-2634

TENNESSEE

CURREY'S, INC. (C/V) • 923-8th Ave., S., Nashville 37203 • 615-242-4223
MILLS MORRIS CO. (C/V/M/A) • 677 Phelan Ave., Memphis 38101 • 901-774-9810
SHIELDS ELECTRONICS SUPPLY, INC. (C/V/M/A) • 4722 Middlebrook Pike, Knoxville 37921 • 615-588-2421

TEXAS

ELECTRONIC COMPONENT (C/V/M/A) • 2401 Bissonnet, Houston 77005 • 713-528-1543
FOX INTERNATIONAL (C/V/M) • 752 So. Sherman, Richardson 75081 • 214-231-1826
M-TRONICS (C/V/M/A) • 3201 West Ave., San Antonio 78213 • 512-340-4069
PORTER BURGESS CO. (C/V/M) • 1233 Levee St., Dallas 75207 • 214-741-5161
SHERMAN ELECTRONICS (C/V/M) • 702 San Pedro Ave., San Antonio 78212 • 512-224-1001
SHERMAN ELECTRONICS (C/V/M) • 1701 Morgan Ave., Corpus Christi 78404 • 512-888-9454
VCP INTERNATIONAL, INC. (V) • 2285 Merritt Dr., Garland 75040 • 214-271-7474

VIRGINIA

AVEC ELECTRONICS CORP. (C/M) • 711 Granby St., Norfolk 23510 • 804-627-3502
AVEC ELECTRONICS CORP. (C/M) • 2002 Staples Mill Rd., Richmond 23230 • 804-359-6071
FAIRWAY ELECTRONICS, INC. (C/V/M) • 2304 Chamberlayne Ave., Richmond 23222 • 804-321-7255

WISCONSIN

DYKRO, INC. (C/V/M) • N90 W14401 Commerce Dr., Menomonee Falls 53051 • 414-255-1900
G.M. POPKEY COMPANY (C/V/M/A) • 2035 Larsen Rd., Green Bay 54307-2237 • 414-497-0400

CODING:

(C) ... Consumer Electronic Parts
(V) ... Vacuum Parts
(M) ... Major Appliance Parts
(A) ... Accessories

* ... Full Line
** ... Panasonic Only
*** ... Quasar Only
**** ... Vacuum Only

(as of 6/30/89)

Matsushita Services Company, 50 Meadowland Parkway, Secaucus, NJ 07094

Circle (14) on Reply Card

REPLACEMENT PARTS SHOWCASE

Matsushita Services Company

50 Meadowland Parkway
Secaucus, NJ 07094
201-348-7589; FAX: 201-348-7527



In addition to service parts, Matsushita Services Company provides Panasonic dealers, distributors and retail stores with pre-packaged Panasonic accessories for display rack sales.

Matsushita Electric Industrial Company (MEI), manufacturer of Panasonic, Technics and Quasar products, is the world's largest manufacturer of consumer electronic products. MEI sales worldwide have passed the \$39 billion mark. At the heart of this success is a tradition of service.

The life blood of Matsushita is a blend of state-of-the-art products, accurate an-

icipation of market demands, effective manufacture and distribution, and a compelling program of sales promotion and marketing. But the heart of its business is the quality of service it renders to each customer.

That's why Matsushita Services Company (MSC) was established to meet the service and parts needs of customers. These customers include Matsushita

authorized servicenters, authorized replacement parts distributors, the nationwide network of Panasonic, Technics and Quasar dealers, and the many millions of Americans who purchase Matsushita products each year.

The total commitment to service quality at MSC is evident everywhere. It is the philosophy that guides every person in the organization. Even if an employee doesn't deal directly with one of the customer groups, the goal of everyone at MSC is to provide excellent service so that customers receive maximum satisfaction of their service needs. The MSC service organization is Matsushita's way of saying to customers, "Thanks for your business and we hope you will select a Panasonic, Technics or Quasar product again."

To meet its service commitment in North America, MSC has a support operation second to none in the consumer electronics industry. A staff of 750 trained men and women provide a wide range of services to customers. Twenty-three MSC factory servicenters (FSCs) are strategically located throughout the country. Technicians in each FSC are well-trained in diagnosing and correcting malfunctions in sophisticated electronic products. Independent authorized servicenters and self-servicing dealers, backed by factory training and a comprehensive stock of original equipment replacement parts, complete the network that makes service easily available to owners of Panasonic, Quasar and Technics products.

SPECIAL ADVERTISING SUPPLEMENT



From headquarters in Secaucus, NJ, Matsushita Services Company (MSC) coordinates a U.S. network of factory servicenters, independent servicenters, self-servicing dealers, parts and accessory stocks and training sessions.



Owners of Panasonic, Quasar and Technic products are never far from factory-trained service technicians.



Factory servicenters at convenient locations throughout the United States provide repair services and replacement parts.



Highly trained technicians use sophisticated instrumentation to speed and improve the quality of customer service.



Trained parts and service personnel provide a telephone link to customers seeking product and service information.

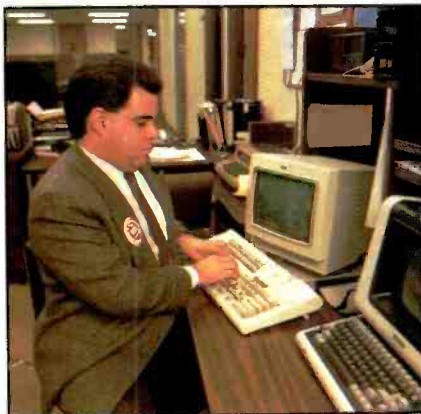

The MSC Parts-Link computer system quickly locates the nearest source of original equipment parts needed to service products.



In thousands of service departments, service procedures developed by MSC speed product repair.

SPECIAL ADVERTISING SUPPLEMENT

MCM ELECTRONICS
PRESENTS:

RCA



NOW YOU CAN ORDER ORIGINAL RCA AND GE
REPLACEMENT PARTS AS CONVENIENTLY AS
ANY OF THE OTHER FINE PRODUCTS IN THE
MCM CATALOG.

OUR IN-DEPTH STOCKING AND FAST
SHIPPING HELP YOU PROVIDE QUICK
SERVICE FOR RCA AND GE REPAIRS.

CALL OUR FRIENDLY SALES STAFF TOLL-
FREE WITH YOUR RCA AND GE PART
REQUIREMENTS AND DISCOVER THE MCM
DIFFERENCE!

CALL TODAY.
1-800-543-4330.



- TELEVISION PARTS
- VCR PARTS
- SERVICE AIDS
- SK REPLACEMENTS

SOURCE NO. ES-47



MCM ELECTRONICS
650 CONGRESS PARK DR.
CENTERVILLE, OH 45459-4072
A PREMIER Company

REPLACEMENT PARTS SHOWCASE

**650 Congress Park Drive
Centerville, OH 45459-4072
800-543-4330; FAX: 513-434-6959**

MCM Electronics is a company of dedicated people committed to offering only the best electronics parts, components and service to the customer.

Because needs in the electronics industry are constantly changing, MCM Electronics continually and thoroughly researches the market and reacts to the market's changing needs. MCM is constantly in touch with national and international manufacturers to bring both commonly used and hard-to-find products to its customers. In fact, three full-sized catalogs are mailed each year, and the last issue introduced more than 500 new items. And recently, MCM became an authorized distributor for more than 3,000 RCA/GE replacement parts.

Sale flyers are mailed regularly, featuring specially priced products. These flyers continually keep the customers informed of new items that are being added.

The sales/customer service department has been thoroughly trained to answer all calls on the toll-free lines promptly and efficiently. These representatives are professionals who can provide immediate information on stock availability and pricing. They are available Monday through Friday, 7 a.m. to 8 p.m. EST, and Saturday, 9 a.m. to 5 p.m. EST. Orders can also be placed after hours with a national, toll-free number, ensuring service 24 hours a day, seven days a week. Technical questions about a particular product can be answered by MCM's highly trained electronics technicians, who are available to provide the answers the customers need.

The company's Distribution Center houses an enormous inventory of parts and components. Every order is pulled and double-checked to strive for timely and error-free shipment. Because more than 14,000 of the items in the catalog are stocked and ready for shipment, orders are shipped within 24 hours.

Even though most orders are shipped by UPS, MCM offers a broad range of shipping options. Customers can establish Net 30 accounts, or they can have their orders shipped COD, charged to MasterCard or VISA, prepaid or picked up at the Distribution Center's Will Call area. There is a \$20 minimum for COD, checks and open accounts, and a \$25 minimum for MasterCard and VISA orders.

For more information and a free catalog subscription, call 800-543-4330 (in Canada, call 800-824-9491; in Dayton, OH, call 434-0031).



SPECIAL ADVERTISING SUPPLEMENT

Circle (15) on Reply Card

Parts Express

340 E. First St.
Dayton, OH 45402
800-338-0531; FAX: 513-222-4644

Parts Express, a full-line distributor of electronics parts and accessories, is geared toward the consumer electronics repair industry, manufacturing design and engineering, and the technical hobbyist. The company stocks an extensive line of speaker drivers and accessories for replacement, plus one of the largest selections of semiconductors in the country. The company offers a free 100-page catalog listing more than 5,000 popular items, and its extensive computer inventory-control system allows it to monitor each item and ensure that it is in stock when you need it.

With both overseas and domestic sources for parts and an aggressive new-product research team, Parts Express keeps in touch with the needs of the industry. It can supply replacement parts for the newest TVs, VCRs and

stereos as they are introduced to the market, and it can special-order non-stocked items for volume users.

The company prides itself on being flexible, and it makes every effort to accommodate special requests. The company normally ships within 24 hours, and most orders received before 1 p.m. EST are shipped the same day. And unlike some companies, Parts Express' service doesn't stop there. The company understands that you aren't always sure what you're getting when you order from a catalog, so it has taken the risk factor out of mail-order. If you are not 100% satisfied with any item you've purchased, you can return it within 15 days for a refund. No questions asked, no restocking fee.

Parts Express can offer a money-back guarantee because it honestly doesn't

think you'll have to use it. On-staff quality-control technicians extensively test and evaluate products before adding them to stock. The company won't sell any item that its technicians wouldn't use themselves.

Call Parts Express at 800-338-0531 for your free issue of the 1989 catalog. They even pay for the phone call. ■

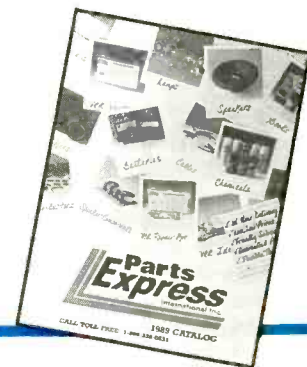

SPECIAL ADVERTISING SUPPLEMENT



OUR NAME SAYS IT ALL !

When we say Parts Express, we mean it! Most orders that we receive before 1:00 are shipped out the same day. And, 99% of all orders are shipped out within 24 hours. You can count on it! Our in-stock ratio is one of the highest in the industry.



PARTS IN STOCK

Our extensive computer inventory control system allows us to monitor each and every line item in inventory to ensure that the item you need is in stock when you need it.



FAST SHIPPING

Our order packing department is experienced at making sure that your order arrives fast and accurately. They pride themselves on quick order processing and few mistakes.



FRIENDLY SERVICE

Our knowledgeable salespeople will do everything they can to answer questions and courteously take your order when you call. We also have experienced technicians on hand if you should need additional technical assistance.



QUALITY

At Parts Express we know the importance of quality parts. We won't sell anything that we wouldn't use ourselves. You can rest assured that we stand behind what we sell. Our 15 day, no quibble guarantee is proof positive of this.

Parts Express International Inc.
340 E. First St.
Dayton, Ohio 45402

Local Phone: 1-513-222-0173
FAX: 1-513-222-4644

CALL
TOLL FREE

1-800-338-0531

Circle (16) on Reply Card

August 1989 *Electronic Servicing & Technology* 45

REPLACEMENT PARTS SHOWCASE

Philips ECG

100 First Ave.
Waltham, MA 02254
800-225-8326; FAX: 617-890-7096

In the electronics servicing industry today, practically everyone recognizes the ECG trademark. It represents the broadest available line of replacement semiconductors and a company that has been meeting the needs of service dealers for 65 years. Today's Philips ECG organization had its roots in the old Sylvania Products Company, which began making receiving tubes for the fledgling radio industry in 1924. Through the years, the Sylvania brand became synonymous with quality, and the company grew to become one of the "big three" in the receiving tube business. During this period, original equipment manufacturers were the principal customers. With the advent of semiconductors, however, fewer and fewer tubes were used in radios and TV sets, and the replacement markets took on added importance. Soon, it became apparent that electronics servicers would also need a wide variety of transistors, rectifiers, diodes and other components to repair the newer equipment using these devices.

Sylvania was one of the first suppliers to identify this need and respond to it. The ECG semiconductor replacement line was introduced in 1967 and quickly became a mainstay product. The first ECG semiconductor replacement guide, published in late 1967, cross-referenced 23 ECG types to approximately 2,700 industry part numbers. The current 14th Edition ECG Guide and its recently published supplement cross some 4,100

ECG types to nearly 250,000 industry numbers. This growth indicates the care taken over the years to ensure that the ECG line kept pace with the industry's needs.

In 1981, GTE Corporation, Sylvania's parent company, sold the Consumer Electronics Group to North American Philips Corporation and this operation's name was changed to Philips ECG. Little else changed, however, as Philips ECG continued to serve the electronics servicing and industrial/MRO markets through a long-established national network of independent distributors. Philips ECG, together with Amperex and Mepco/Centralab, is currently part of Philips Components, a North American Philips Company. That's our background. Now, let's talk a little about how Philips ECG operates.

All Philips ECG products are sold only through authorized distributors. These distributors maintain sufficient inventories to provide off-the-shelf delivery in most cases. In the rare instances where a product is not in stock, distributors can access the Philips ECG Distribution Center via toll-free telephone and telefax lines. When the customer specifies "Hot Line" service, the products can be shipped within 24 hours.

The Distribution Center, located in Williamsport, PA, serves as the focal point for the company's activities. The modern, 105,000-square-foot facility includes warehousing, customer service, finishing, engineering and product

marketing, data processing and administrative departments. It is fully equipped and staffed to provide Philips ECG distributors with prompt, efficient service. The engineering department also offers direct assistance to distributors' customers who require technical information not otherwise available.

In addition to the ECG Semiconductors, current Philips ECG product lines include digital and analog multimeters, digital thermometers, logic probes, electromechanical and solid-state relays, surge suppression devices, audio-video parts and accessories, flameproof resistors, TV converters, aerosol chemicals for electrical and electronic applications, solder wire, desoldering braid and antenna rotators. These lines are continuously monitored and updated to ensure that Philips ECG customers receive the latest in state-of-the-art technology.

Philips ECG has its headquarters in Waltham, MA, and is under the direction of Donald R. Kronenwetter, vice president and general manager. All ECG products are managed by L. Randall Brophy, business unit general manager, located in Williamsport, PA.

After 65 years of service to the electronics industry, Philips ECG looks forward to continuing this tradition for many more. Sincere thanks to the loyal customers who have supported us and continue to do so through their purchases of ECG products. ■



This Rapid Pack equipment automatically loads ECG replacement semiconductor products into individual plastic packages, imprints the type number on the label and seals the plastic bag for storage or shipping. Rapid Pack machines perform this operation 32 times per minute.



In this operation, ECG replacement semiconductors are packaged in boxes by equipment that imprints type numbers and basing diagrams of the devices on the individual cartons. The machine indexes 40 times per minute and can accommodate all semiconductor carton sizes.

SPECIAL ADVERTISING SUPPLEMENT



THERE IS NO SMARTER CHOICE THAN PHILIPS ECG.



ECG PR200A OR PR60: FOR THE RIGHT ANSWER TO YOUR SCOPE PROBE NEEDS.

ECG scope probes come packed with features and packed with value. Features on the PR200A include:

- 200 Mhz bandwidth capability
- X1, X10 attenuation and reference switch
- Low input capacitance
- Large thumb switch with positive detents, for easy switching between X1 and X10 and ground reference
- Comes with an IC tip, BNC adaptor, insulating tip and a retractable hook

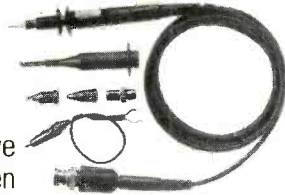

The PR60 features:

- 60 Mhz bandwidth capability
- X1, X10 attenuation and reference switch
- Retractable hook

ECG scope probes: the smart choice.

Circle (17) on Reply Card

ECG REPLACEMENT PARTS KEEP VCR's IN TOP SHAPE.

To replace VCR mechanical parts, look no further. Our full line can replace mechanical parts for all major brands of VCR's, and our catalog contains the most accurate cross-references by brand name, part number, and model number.

- Line includes 13 pinch rollers, 42 idler wheels and assemblies, 4 idler tires, and 48 belt kits
- Individual belts available



VCR mechanical parts from ECG: the smart choice.

Circle (19) on Reply Card

ECG DM-26 AND DM-27 FULL FUNCTION GENERAL PURPOSE MULTIMETERS.

The ECG DM-26 and DM-27 multimeters are loaded with features and loaded with value. Just check out the array of capabilities:

- Diode test
- Rotary range switch
- Tilt stand
- 0.8% basic DC accuracy
- 3 1/2" digit LCD display, 0.5" high
- 20 MΩ full scale
- 10 MΩ input resistance, DC
- Low power Ohms
- Overload protected
- The DM-27 also includes an audible continuity test



ECG multimeters: the smart choice.

Circle (18) on Reply Card

ECG CABLE CONVERTERS BRING IN THE SIGNAL LOUD AND CLEAR.



- The TV 2000 adapts any TV set to cable-ready
- Remote control adjusts volume, turns TV on/off, has direct channel selection and channel stepping
- Receives up to 139 VHF, UHF and cable channels
- Separate video and audio outputs for direct connection to VCR and stereo systems
- Stores up to 12 user-selected channels for quick selection

ECG cable converters: the smart choice.

Circle (20) on Reply Card

Philips ECG Company

A Division of North American Philips Corporation
© 1989, Philips ECG Company.

Contact one of more than 900 distributors or call 1-800-225-8326 for the name of the distributor nearest you. It just might be the smartest call you make all week.

PTS

**5233 S. Hwy. 37
Bloomington, IN 47401
800-333-PTS-1; FAX: 812-824-2848**

PTS is the world's largest independent supplier of exact replacement parts for all makes and models of TVs and VCRs.

Exact is the key word. The company takes pride in its expansive inventory: literally thousands of TV modules and tuners, as well as VCR heads, idler assemblies and belt kits. And PTS standards are precise and exacting. All parts meet or exceed manufacturers' specifications.

Ordering from PTS is easy and quick. There's a toll-free number (800-333-PTS-1) for placing orders, and turnaround time is swift. Orders received before 2 p.m. are shipped the same day. Customers who request shipment via Federal Express pay as little as \$2 more than UPS surface rates. That ensures next-day delivery to your place of business. PTS also accepts VISA and MasterCard.

There's another cost advantage. "Our prices represent savings of up to 40% from manufacturers' list prices," says Jeff Hamilton, executive vice president. "We believe that our easy ordering and quick delivery system, the precision quality of our parts and modules and our pricing structure make PTS really the only choice when it comes to repair parts and modules for consumer electronics."

PTS stands behind what it sells. Jack Craig, company president, says, "Every item in our inventory is guaranteed to be an exact replacement and is covered by the best warranty in the business."

The PTS inventory is so vast that back orders for most parts are virtually unheard of. "We know you need parts in a hurry, and we are committed to filling your order immediately," says Craig. Helping to meet that commitment are the professionally trained PTS customer service representatives and a nationwide network of stocking distributors. When you request a part, they know what you're talking about.

But PTS is not just a company of order-takers. Engineers and factory-trained technicians make up a great portion of the staff. It is they who monitor the quality-control standards demanded by thousands of professionals nationwide who order from PTS.

PTS also offers remanufacturing and repair services. Television tuners and

modules are restored to original condition quickly and efficiently. On those rare occasions when a module is out of stock, the PTS technical staff will speedily rebuild the defective part.

A new component of the PTS business is a complete remanufacturing service for computer disk drives and computer monitors. This work is guaranteed to meet or exceed manufacturers' specifications. Precision quality is demanded in all of PTS' varied operations. Other rebuilding services include TVRO equipment, VCRs, camcorders and appliance touch-control panels.

This repair/remanufacturing aspect of PTS is a rapidly growing part of the company's business. But the company has built its reputation on providing service technicians with all makes and models of quality, exact replacement parts for TV repair with overnight service.

David Melwid, product sales manager, says, "We have worked extremely hard to establish the kind of a replacement-parts service that the industry can rely on and believe in. That's why we have been so intent on developing this company into what we call the 'world's largest independent supplier of exact replacement parts.'"

The response to the toll-free number

has exceeded the company's expectations. "It's been fantastic," Melwid says, adding, "We're pleased to know that PTS products are in such great demand and that our parts are held in such high esteem by the nation's consumer electronics service stations."

PTS has had a phenomenal growth in the 20 years since its founding in a converted garage in Bloomington, IN. From that humble beginning, it has expanded to a network of computerized warehouses, state-of-the-art manufacturing facilities for the repair and remanufacturing processes, and a modern, well-equipped office where orders are taken and processed. The company now employs 550 people.

PTS operates product and service outlets at other strategically located sites in Tampa and Sarasota, FL; Arvada, CO; Longview, TX; Cherokee, NC; Fenton, MI; Fife, WA; Schenectady, NY; Ventura, CA; and West Columbia, SC.

Thus, the PTS system of exact replacement parts is readily accessible to electronics service professionals from coast to coast. The products and services of the company are as close as the telephone: 800-333-PTS-1. Call weekdays between 8 a.m. and 5 p.m. (EST) and Saturdays from 8 a.m. to noon. ■

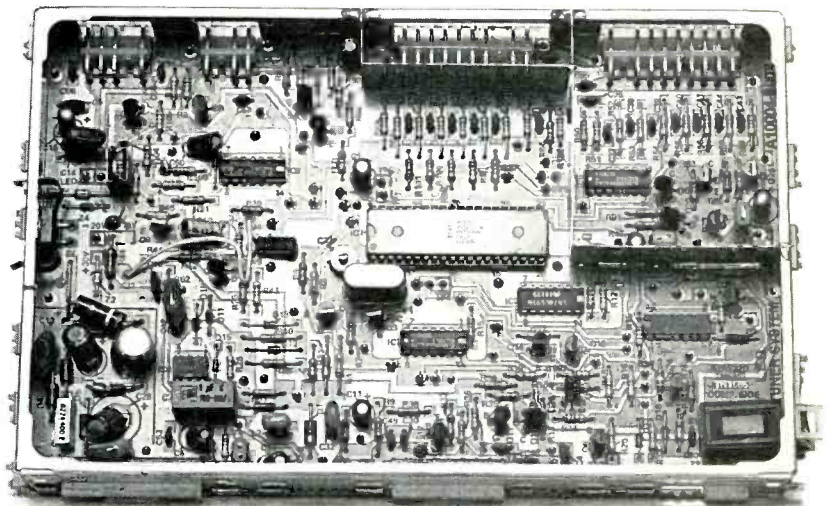

PTS has the world's largest inventory of exact replacement modules in stock for immediate delivery.

The only difference is the price.

MODULE PRICE COMPARISON*

General Electric

	OEM	PTS
EP93X103	37.55	28.65
EP93X237	56.60	45.25
EP93X235	61.80	46.05
EP93X175	57.00	48.85
EP93X168	75.90	68.75

Magnavox

	OEM	PTS
703744-6	49.75	43.95
703646-1	58.20	42.90
APW002B002	95.95	84.15
A10002A002	85.85	64.50
EME101A001	162.15	127.15

RCA

MDR001A	23.60	18.54
MTT001A	95.20	70.00
MSC013RA	79.70	64.17
MAH001B	29.95	19.22

Zenith

	OEM	PTS
9-160	83.45	76.95
9-155-01	33.36	22.05
9-147	31.97	26.30
9-90	23.63	15.90

Sylvania

	OEM	PTS
02-45719-3	64.35	50.95
02-37503-3	82.60	55.95
02-3017074-1	147.25	125.30

* Quoted prices are outright purchase including dud value.

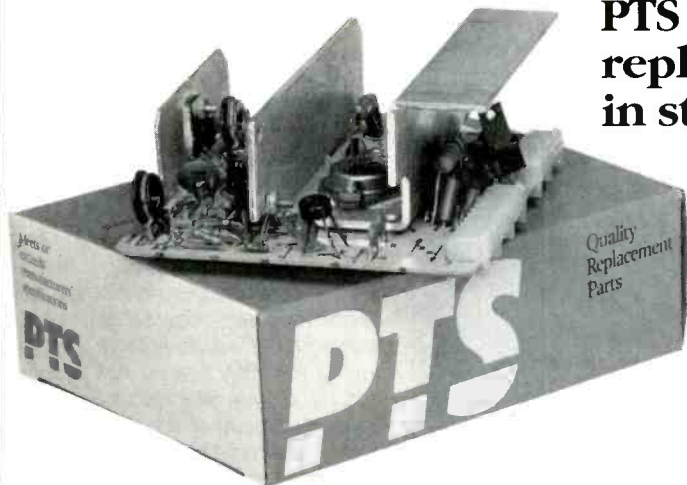

PTS has thousands of exact replacement parts and modules in stock at savings of up to 30%

- All makes, all models
- Thousands of modules in stock
- Every module guaranteed for exact replacement
- 100% module air testing in live chassis
- Full one-year limited warranty
- Every module meets or exceeds manufacturers' specifications
- Automatic updates
- Toll-free order convenience
- Federal Express overnight shipping
- Fast 24-hour rebuilding service.

► Call today for your FREE price guide. Compare today and save!



TRY PTS TODAY • CALL TOLL FREE!

1-800-333-PTS1

5233 South Highway 37
P.O. Box 272
Bloomington, IN 47402



Additional PTS Servicenters • Arvado, CO • Cherokee, NC • Fenton, MI • Fife, WA
• Longview, TX • Sarasota, FL • Schenectady, NY • Tampa, FL • Ventura, CA • West Columbia, SC

Circle (21) on Reply Card

NTE Electronics

44 Farrand St.
Bloomfield, NJ 07003
800-631-1250; FAX: 201-748-6224

At NTE Electronics of Bloomfield, NJ, the concept of less is more is at the heart of meeting the requirements of consumer electronics servicing professionals: Less inventory to manage and less downtime means more efficient operations and more happy customers. NTE calls its program *replacitivity*. It is the science of keeping things up and running.

NTE has grown from a small-town supplier to one of the top replacement semiconductor sources in the United States in 10 short years by showing serv-

icing professionals and component distributors how they can reduce 235,000 industry part numbers to just 3,400 cross-referenced replacement components. At the same time, NTE's "replacitivity" concept has spread around the globe. Today, its market scope includes Canada, Latin America, the Caribbean, Europe and even the Middle East.

William Horstmann, vice president and general manager of NTE, shed some light on the company's success. "From our inception as a company with

just 10 replacement parts in our line, NTE has placed an emphasis on developing a well-earned reputation for quality, service and value," said Mr. Horstmann. "As a result, our annual catalog has practically become a bible of the replacement parts industry. All of our parts are double-checked on state-of-the-art equipment to ensure they meet or, in most cases, exceed the specifications of the original parts. In fact, we're so confident about the quality of our replacement parts that we offer an exclusive 2-year warranty on every one!

"The success of NTE's replacement parts program in the United States naturally led us to explore Europe, with its transborder business opportunities," continued Mr. Horstmann. "In preparation for the 1992 elimination of trade barriers, NTE is working to be up and running within the European marketplace for the dawning of that new era. Our plan of action is well ahead of schedule."

Both in the United States and abroad, NTE offers buyers something more than just value. That "something" is NTE's program of cross-referencing, better inventory management, quality and service.

"Downtime is costly," explains Mr. Horstmann. "No one can afford to wait weeks on end for an OEM part to come in. With NTE, no one has to! One call to our authorized distributors gives service professionals access to a broad line of universal replacement parts. We ship immediately so downtime can be reduced to a day or two, not weeks. The quality of our replacement parts also helps assure that repaired equipment stays repaired, which means servicing professionals will retain their customers and their profit."

For a copy of the NTE Technical Guide and Cross Reference, contact your local NTE distributor or NTE Electronics, located at 44 Farrand St., Bloomfield, NJ; 800-631-1250 (outside New Jersey), 800-624-2624 (New Jersey only). FAX: 201-748-6224. ■

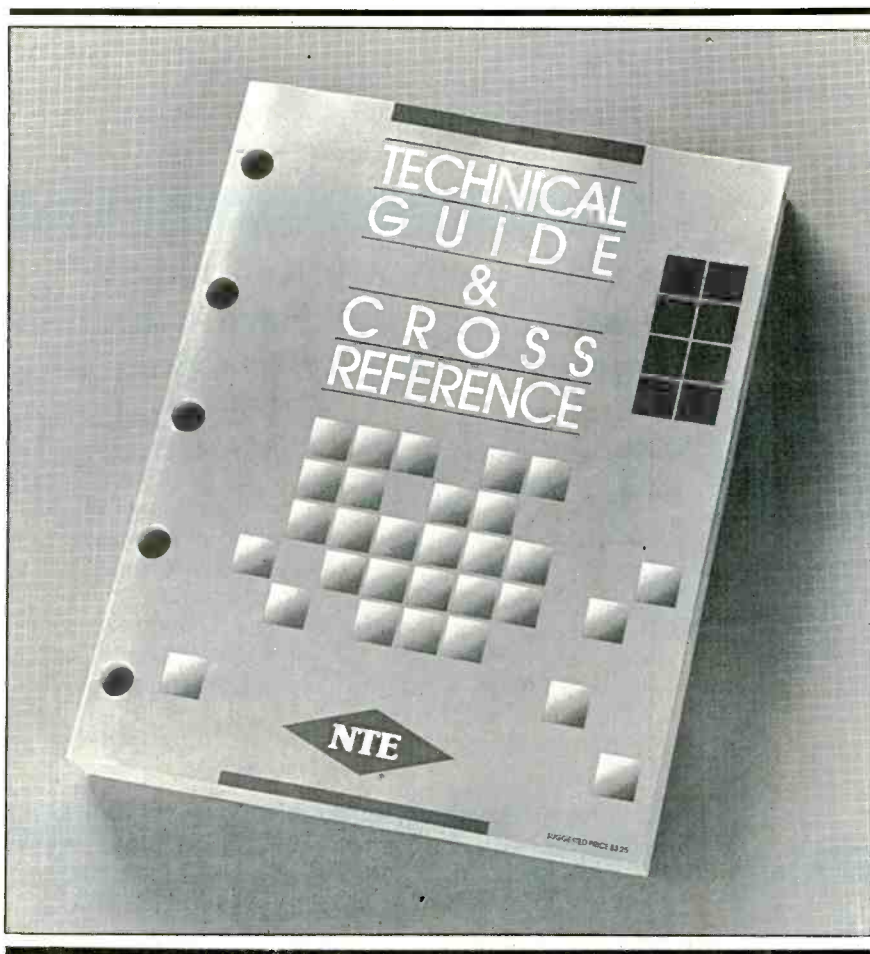

NTE KEEPS YOU UP AND RUNNING.

NTE specializes in "replacitivity," the science of getting things up and running again—fast! After all, downtime is costly, so no one can wait weeks on end for an OEM part to come in. With NTE, no one has to! One call gives you access to 3,400 top of the line universal replacement semiconductors that are cross-referenced to more than 235,000 original devices! Included in the NTE line are: bipolar transistors, integrated circuits, rectifiers, diodes, thyristors, optoelectronic devices, varistors, resistors, capacitors, and much, much more. All are backed by NTE's exclusive two-year warranty.

For your copy of the NTE Technical Guide contact your local NTE distributor, or simply fill in the coupon below and send it to us today with a check or money order for \$3.25 each.



NTE ELECTRONICS, INC.

A WORLDWIDE REPUTATION FOR QUALITY, SERVICE AND VALUE

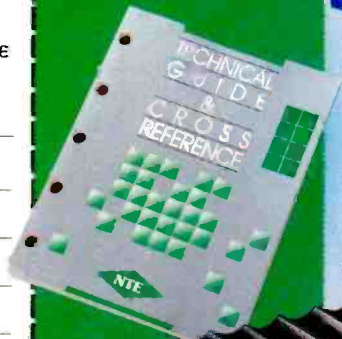
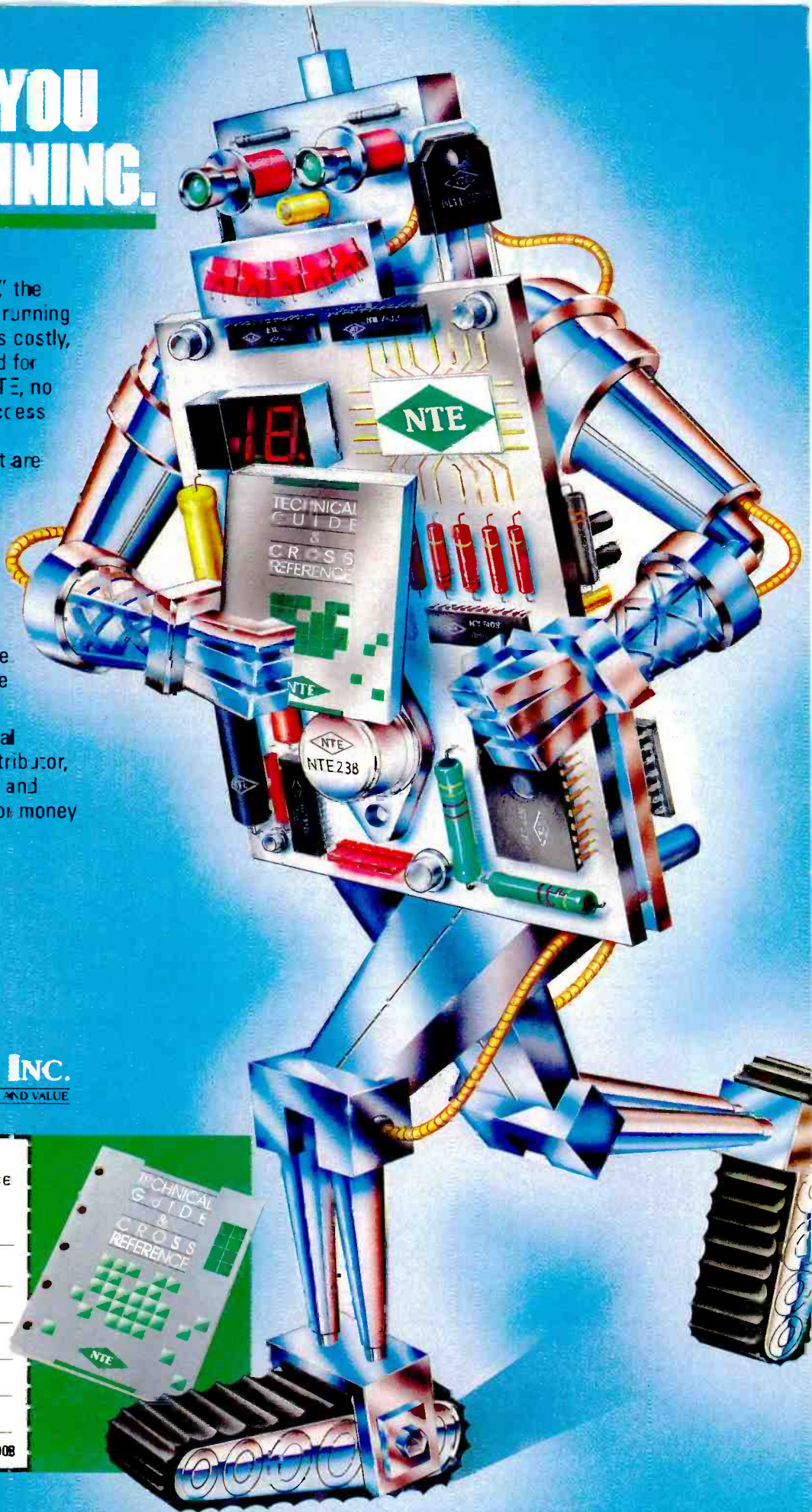

Please rush me _____ copies of the NTE Technical Guide and Cross Reference manual at \$3.25 each. I have enclosed my check or money order for a total of \$ _____

Name _____

Company _____

Address _____

City _____

State _____ Zip _____

Mail to: NTE, 44 Farrand St., Bloomfield, NJ 07008

ES&T 8/89

FOR THE NAME OF YOUR NEAREST NTE DISTRIBUTOR, CALL NTE TOLL FREE: OUTSIDE NJ 1-800-631-1250 • INSIDE NJ 1-800-624-2624

Circle (22) on Reply Card

www.americanradiohistory.com

Using logic in troubleshooting

— Part II

By Stewart Leabman

The tendency to memorize symptoms and cures for a particular model of VCR is natural enough, and it can save a lot of troubleshooting time once you identify a recurring problem. However, if your troubleshooting skills are suffering from lack of use, you might be relying on memory too much and forgetting how to logically troubleshoot a not-so-obvious problem.

Last month we related two case histories in which good basic troubleshooting skills could not be replaced by symptom/cure memorization. Here are two more examples of problems that require a good understanding of how electronic circuits work.

Bad on-screen display

A Mitsubishi VCR that came into my shop for repair really illustrated that the best way to find the exact cause of a problem in a VCR is to take logical steps in the proper order to find the defective circuit, then narrow it down to the defective part. It sometimes happens that the

Leabman is a senior technician in a Trenton, NJ, service lab.

part that appears to be bad is not the defective part at all. Instead, another part or a bad connection might be causing the problem.

I had a Mitsubishi HS-422UR with a defective on-screen display (OSD), which appeared garbled on the picture. It appeared that the horizontal hold was off on the OSD, although the video looked normal.

The OSD IC (IC5A3) is on the mechanism control PCB, so I started there by measuring each pin on IC5A3. The oscillator was running at pins 6 and 7. V-SYNC was present at pin 13, but H-SYNC at pin 14 was not present. I traced the signal back to connector CK, pin 16 on the mechanism control PCB labeled C-SYNC and, in turn, to connector SK, pin 16, on the signal PCB.

On the signal PCB, C-SYNC is routed directly from connector SK, pin 16, to connector SL, pin 3, which goes to connector AL, pin 11, on the MCS PCB. On the MCS PCB, C-SYNC comes from the collector of Q2001, which is driven by pin 3 of IC2001. At this point, the signal was still missing.

Tracing the signal back through IC

2001, I found that the 3.58MHz signal was missing at pin 6 and at connector AL, pin 10, which goes back to connector SL, pin 4, on the signal PCB. (See Figure 1.)

Tracing back from connector SL, pin 4, on the signal PCB, I found that the dc voltage at the emitter of Q6A2 was 5V, the collector of Q6A2 was 5V and the base was about 3V. Because the base voltage was below the emitter voltage, the transistor was cut off, so it did not pass the signal from the base to the emitter. The base had the 3.58MHz signal, but the emitter did not.

Again, as in the first example last month, the problem turned out to be a blob of glue on the printed circuit board at Q6A2. The glue had become conductive, shorting the emitter to the collector. I removed the glue and the on-screen display became functional.

Having some symptoms you can memorize is a great bonus for the servicer, but it should never replace a logical troubleshooting method. In each of these cases, thinking through the circuit to the most logical point and troubleshooting from there shortened the time I spent probing, desoldering and tracing.

Rolling picture

If you don't understand the function of a particular component, it's difficult to logically troubleshoot forward in the circuit. In those situations, the best way to approach the problem sometimes is to start from the end and work back to the beginning. In this case — a Mitsubishi HS-411UR with a rolling, distorted picture — the exact function of the defective circuit is not explained in the service manual, but it was not necessary to know what it does to the signal to find the defective part in that circuit.

At the video output jack and at the video input to the RF converter, the video had spikes on all of the horizontal sync pulses and the equalizing pulses. The problem was that the vertical sync pulse had spikes on it, which was causing the picture to roll.

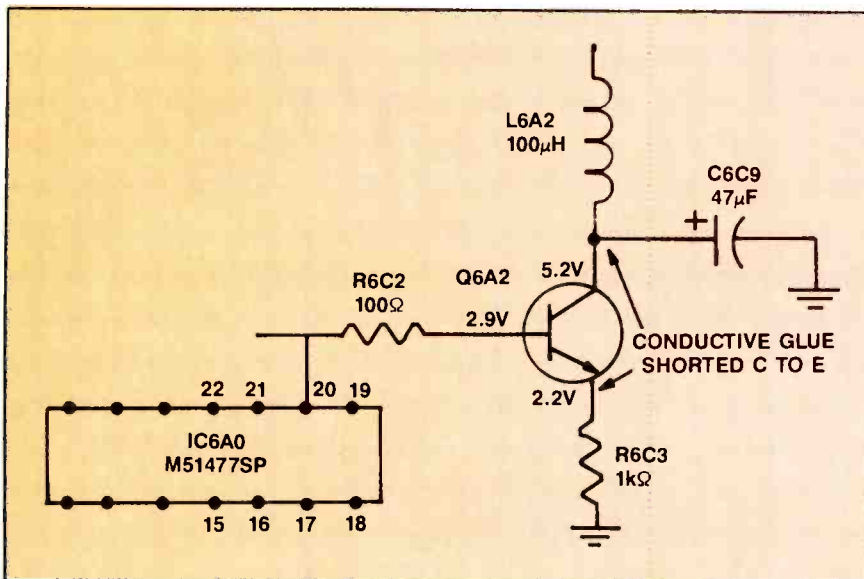

Figure 1. The base voltage was lower than the emitter voltage of Q6A2 in this Mitsubishi HS-422UR. The problem was conductive glue on Q6A2, which shorted the emitter to the collector and resulted in bad on-screen display.

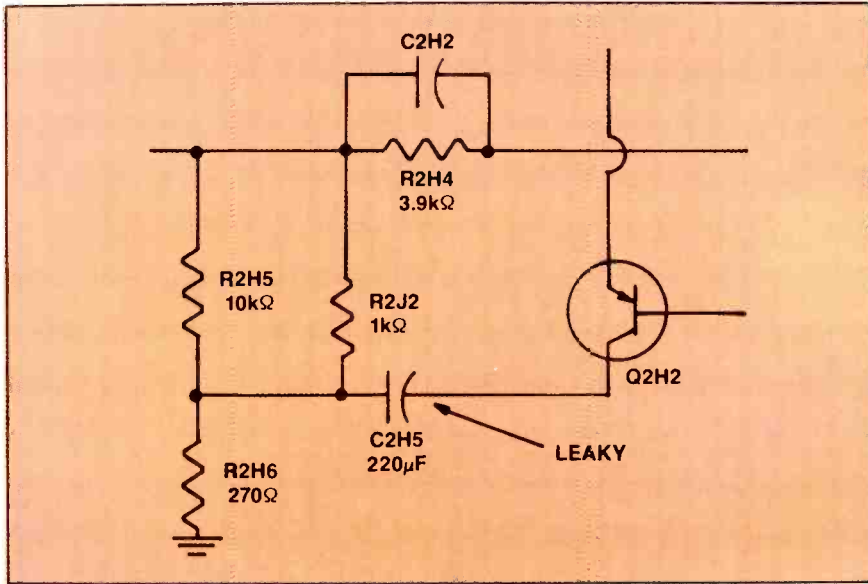

Figure 2. A leaky C2H5 capacitor was affecting the luminance signal, causing the rolling, distorted picture.

Starting at the video output and tracing the signal back on the Y/C PCB, I found that the video signal was distorted

back through Q2CO, the video buffer transistor, to pin 8 of IC2AO. Tracing the Y (luminance) signal back inside of

IC2AO, I found that it comes into pin 35 from a circuit external to the IC. Tracing through the circuitry external to IC2AO, I found that it leaves IC2AO, pin 27. The signal was normal at pin 27, so it was affected in the external circuitry.

Tracing from pin 27, I found that the luminance signal goes through a low-pass filter to the base of Q2A2, comes out the emitter of Q2A2 to the emitter of Q2HO, out the collector of Q2HO to the base of Q2HI, then out the emitter of Q2HI to the base of Q2H3. The signal was good at the emitter of Q2HI and bad at the base of Q2H3. Something in the circuit with Q2H2 was causing the problem.

Mitsubishi does not show or tell what the function of Q2H2 is and it is not shown on the block diagram. I checked the transistor and it was good. Checking the other few components in that small section of the circuit, I finally found that C2H5, a 220μF (6.3V) electrolytic capacitor, was leaky. Replacing the capacitor cured the problem. ■

REPRINTS

Interested in ordering article reprints out of this or another issue? * Reprints can be excellent learning tools for your technical staff and great marketing tools for your sales staff. Call or write Kelly Hawthorne at Intertec Publishing Corp., P.O. Box 12901, Overland Park, KS 66212; (913) 888-4664.

* Minimum order 500 copies.

Heathkit®

A leader in quality electronics for the technically sophisticated customer.

When you need kit or assembled electronic products for work, home or hobby, you can be sure Heathkit products are designed to perform reliably and effectively...year after year.

See what we have to offer. To get your **FREE Heathkit Catalog**, fill out and mail the coupon below or call toll-free today!

1-800-44-HEATH
(1-800-444-3284)

YES! Please send me a **FREE** copy of the Heathkit Catalog.

Send To: Heath Company, Dept. 030-804
Benton Harbor, Michigan 49022

Name _____

Address _____

Apt. _____

City _____

State _____

Zip _____

A subsidiary of Zenith Electronics Corporation

CL-801

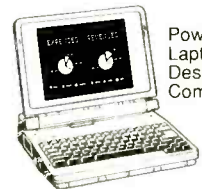

Powerful Kit Laptop and Desktop Computers



Precision Test Instruments

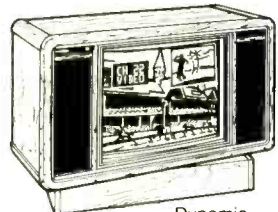

Dynamic Home Entertainment Products

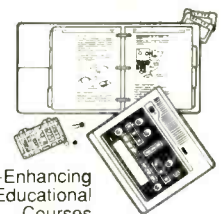

Skill-Enhancing Educational Courses and Trainers

Troubleshooting problems in the de-emphasis circuit – Part II

Last month's installment of Audio Corner introduced one of the less well-understood circuits in audio servicing — the de-emphasis circuit. Part I discussed why pre-emphasis and de-emphasis are used and how the pre-emphasis circuit works. This month, we'll focus on de-emphasis.

The de-emphasis network

At the receiver, pre-emphasis must be reversed with a de-emphasis network in order to restore the audio signal to its original condition. A de-emphasis network similar in principle but opposite in effect to the pre-emphasis network is used. Figure 1 shows a typical example of a de-emphasis RC circuit, consisting of an RC low-pass filter with a 75µs curve, and the resulting de-emphasis curve. The chart shows how the output voltage decreases higher audio frequencies. Notice how this chart and the de-emphasis curve are exactly the opposite of the pre-emphasis curve and chart shown last month.

Locations of the networks

At an FM broadcast or TV station, you will find the pre-emphasis network located in the L+R audio signal path as shown in Figure 2. This signal contains the combined left and right channel frequencies, which then deviate the carrier. This L+R signal is the main audio channel and provides compatibility with non-stereo (mono) receivers. Because the pre-emphasis network is applied to the L+R signal at the transmitter, an equivalent de-emphasis network is needed by both stereo and mono receivers.

The location of the de-emphasis network will be slightly different depending on whether it's in a stereo or a mono receiver. In a mono receiver, you will find the de-emphasis network at the output of the FM detector before the first audio amplifier. In the older FM receivers, it would be on the output of

the discriminator or ratio detector. In modern integrated-circuit FM and TV mono receivers, an external capacitor or RC network to the IC provides the de-emphasis. These components are associated with the IC at the output of the detector.

In FM stereo receivers used in FM and TV audio reception, you will find a de-emphasis network located in the L+R signal path. This network is found after the low-pass filter separates the L+R stereo signal from the other stereo information and before the stereo matrix

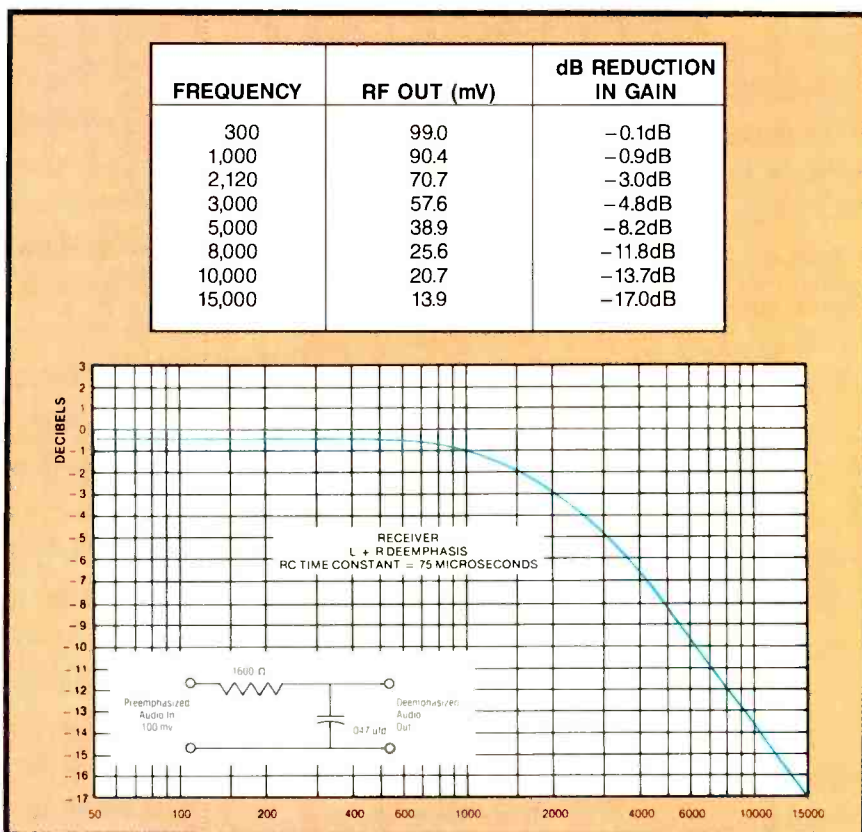

Figure 1. An RC filter at the receiver provides de-emphasis or reduction of signal voltages at the higher audio frequencies. It is exactly the opposite of the transmitter pre-emphasis curve.

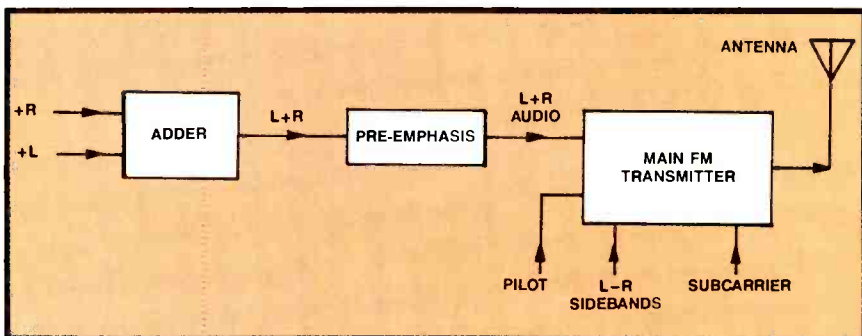

Figure 2. Because the pre-emphasis network at the transmitter is located in the L+R audio path, both mono and stereo receivers must also have a de-emphasis network.

Adapted with permission from Tech Tip #123, "Understanding Pre-emphasis and De-emphasis," published by Sencore, Sioux Falls, SD.

stage recovers the separate left and right audio signals. Figure 3 shows examples of de-emphasis networks.

De-emphasis and the technician

The RC de-emphasis network plays a vital role in accurately reproducing the high-fidelity FM and TV audio signal. A failure in the network, such as a bad capacitor, will alter the audio frequency response of the receiver. Knowing how to determine whether the de-emphasis is working can save valuable servicing time.

Testing the audio section of a TV receiver requires an FM carrier generator and an output indicator. To test the audio frequency response of the receiver and the de-emphasis network, you can use a test device that generates an FM carrier which can be modulated at audio frequencies both below and above those affected by the de-emphasis network.

To test the output signal power of the receiver, you must monitor it with an oscilloscope or output power meter. If

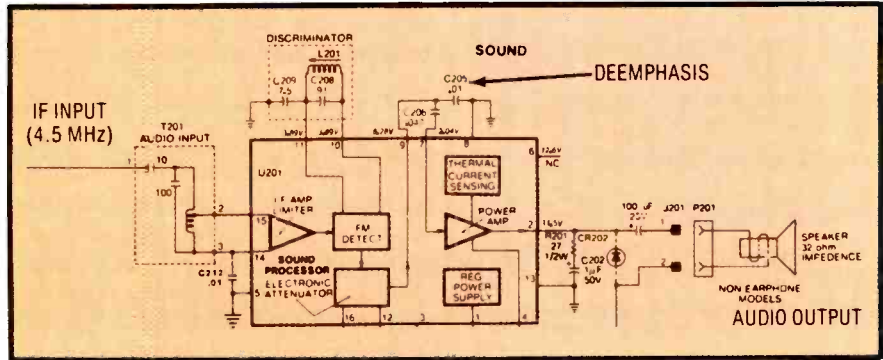

Figure 3. De-emphasis components are located external to the integrated circuit in the TV sound system.

the de-emphasis circuit is operating properly, changing the audio output of the generator from 1kHz to 5kHz should cause a 7dB reduction in output power. A change from 5kHz to 7kHz should result in an additional 3dB reduction in audio power. These are normal decreases in receiver audio output power caused by the response of the de-emphasis network. Measured values should closely follow the de-emphasis curve in Figure 1.

If the output levels do not conform to the de-emphasis curve, you should check the output of the de-emphasis network. Monitoring the output power from the de-emphasis circuit should also show reductions in audio power. If this output is not seen, you should check the de-emphasis network and detector circuit. If the response is normal at the output of the de-emphasis but not on the output of the receiver, the audio amplifier is not working properly. ■

ISCET

VCR

Cross Reference

VCR Model Number Cross Reference
and VCR Parts Cross Reference

A 256-page document that contains both
model and part number cross-references.
Published by ISCET in conjunction with ASEA.

Updated, January 1989
Only \$36 each includes postage

Allow 4-6 weeks delivery when using personal checks or VISA and MasterCard. Money orders and cashiers checks processed immediately.

Amount _____ VISA MasterCard
 Card No. _____ Exp. _____
 Name _____
 Business _____
 Address _____
 City _____ State _____ Zip _____
 Phone _____ Member: ISCET; NESDA
 Texas residents multiply dollar value x 7 1/4% for taxes.
 Foreign shipments please add International postage.
 Send to: ISCET, 2708 W. Berry St., Ft. Worth TX 76109

Presenting an affordable Light Box System.

Model TR100 CB
Camera Light Box
with (2) transparencies

- (2) 3200° Kelvin Lamps (meets mfr. spec.)
- 1-year conditional guarantee
- Transparencies mounted in acrylic with optical scratch-resistant surface
- 11-step gray scale transparency
- 7-Bar color transparency
- All orders are shipped within 72 hours, U.P.S.

The method most manufacturers recommend

NUTRONIX (313) 939-2740

P.O. Box 77103 • Sterling Hts., MI 48077

Circle (10) on Reply Card

Have a question, a correction, an opinion? Drop us a line. If the subject matter would be of general interest to the ES&T audience, we'll publish it here. Send your feedback to:

Conrad Persson
Electronic Servicing & Technology
P.O. Box 12901
Overland Park, KS 66212

VCR rebuilding

In the May 1989 issue of ES&T, I read the Video Corner by Stephen J. Miller titled "Rebuilding VCRs." Mr. Miller writes, "Good repairs that last will result in numerous referrals generated by your satisfied customers, with an attendant increase in business and, thus, revenue."

I agree with this philosophy in theory, but Mr. Miller, a technician in a Lancaster, PA, repair company, doesn't make clear the additional cost, if any, paid by customers for the additional work done beyond repairing the customers' VCRs. Mr. Miller doesn't say whether Lancaster, PA, is nearer to Camelot or Utopia, but I suspect it can't be far from either one. Mr. Miller also doesn't say what "The Boss" thinks of his philosophy.

Here on Long Island, NY, many of my customers don't bother to get the VCR fixed until two or three problems make it unusable. I have a policy: \$20 minimum bench charge for adjustments and diagnosis (payable when the machine is brought in); cleaning heads and mechanism is \$45, including the bench charge; mechanical repairs are \$75 for labor (parts additional), including the bench charge; and electronic circuit repairs are \$45 per hour (parts additional).

Most customers want their VCRs repaired as quickly as possible "for the children" or, as I say, "to relieve the withdrawal symptoms." Most customers are willing to pay a fair price to repair the complaint and check the VCR for proper operation, but most don't want to pay extra for repairs that appear to them to be unnecessary.

As the owner of a one-man shop, I try to take a middle ground. I listen to what the customer tells me about how much he thinks the VCR pays to fix, and I respond accordingly. Sure, I want happy customers too, but if my customer wants me to do a \$125 repair but only charge

\$75, I explain why I can't do that.

Alan Scott Dodge
Long Island, NY

Yes, the customer does pay for all additional parts. In addition, should the installation of these additional parts require significant extra time, the customer is billed for this also. In most instances, the high failure-rate parts are inexpensive mechanical parts that require very little time to install, once you have the unit disassembled. Thus, on many machines, rebuilding is not drastically more costly than just repairing.

My employer also believes in rebuilding units. We try to incorporate the idea even into the TV and audio products we service.

As for ensuring quick turnaround time, I stock all the parts for the rebuild kits at all times. Often I have everything needed to complete the repair on hand.

We, at this shop, do not charge additional labor on any unit returning for service within 30 days for the same or similar complaint. Therefore, should we omit the rebuild parts and one of these parts fails within 30 days, we must eat the second labor bill. Another hidden cost in these repeat calls is the time spent dealing with an irate customer.

Most customers will understand the wisdom of installing the extra parts if the cost is not prohibitive and you make it clear that changing these parts now will increase the time interval between repairs. Selling additional "soon to fail" parts is not a new concept. I wonder how many readers purchased a new air filter for their car during their last oil change because the mechanic said it would be due for replacement soon?

Should the customer refuse to OK the installation of all the parts you feel are necessary, be sure to note this on the bill. This type of documentation will be very useful if the customer later complains about the performance of the equipment.

Finally, I respect your opinions, even though they may differ from mine. As a service-only repair shop, we have found that rebuilding units helps us to maximize profits. Other shops may find that a different tack works better for them.
Steven Miller

Formatting disks

After reading your article in Com-

puter Corner (May 1989), I felt that I should share a similar and related problem with you that may explain the results you found in formatting the 1.2M disks. This related problem was first discovered on a large, installed base of 360K floppy drives in IBM PCs. It was initially discovered that a floppy disk formatted on a 1.2M drive at 360K would not read on some drives and would on others. The initial thought was that some of the disk drives were out of alignment. However, after some further investigation, it was discovered that the head size on the 1.2M is much smaller than on the older 360K drives. This difference means that the track size written to on the disk by the 1.2M drive is much smaller, and many of the older 360K drives don't have the head sensitivity to read the information.

I believe that this is related to the problem you are experiencing. The newer disk drives are increasingly sensitive in order to lessen the problems with the disk drive/floppy disk alignment mismatch. Many newer 1.2M drives will read and write to disks with a quality that a few years ago would not have worked. It is also interesting to note that the sensitivity of a drive varies greatly between manufacturers.

Mitchell S. Cottrell
Sr. Research Electronics Technician
University of Missouri-Rolla
School of Engineering
Rolla, MO

A figure switch

I just received my June issue of ES&T, and I was scanning through some of the articles when I came across Mr. Arso's column about equivalent series resistance in the Audio Corner.

I was reading through and all information and text seemed logical and I could follow along quite nicely. When I referred to the figures, I found them to be supportive also, until I tried the related math in my head. I then re-read the text and checked over the diagrams (Figures 2 and 3) and there I noticed what happened. The printer goofed and reversed the figures with the numbers!

Wayne Doganieri
Cinnaminson, NJ

You're absolutely correct. The figure captions for Figures 2 and 3 were reversed. Sorry about that.

Conrad Persson ■

Readers' Exchange

NOTICE: AS OF THE OCTOBER ISSUE, ES&T WILL CHARGE A SMALL FEE FOR READERS' EXCHANGE ITEMS.

To more efficiently process Readers' Exchange items and to assure more timely ad turnaround, the Readers' Exchange department will be turned over to the Classifieds staff as of the October issue. Prices for Readers' Exchange and Classifieds are as follows:

- Readers' Exchange: 50 cents per word.
- Classified Ads: \$1.65 per word.

Readers' Exchange will continue to cover only Wanted and For Sale items. Specialized heads, such as Job Opportunities or Help Wanted, must continue to run in the Classified section. Please see the Classifieds in this issue for details on word counts, etc.

To get into the last free Readers' Exchange, send in your item by August 11, 1989. Readers' Exchange items received after August 11 that are not accompanied by a check will be discarded.

WANTED

Clock crystal for a 1966 Zenith model #X179G clock radio; Sams sets 638, 100; 1949 Admiral TV

knobs 33C53-T1, T2, T3, T4; tuning eye EM34/6CD7; latest roll chart, roll book for Jackson tube tester 658A. *J. De Lasse, 17 Seldin Ave., Richmond, NY 10314; 718-981-1218/761-6559.*

Novelty and character radios — tube-type radios with characters on the front (Snow White, Mickey Mouse, Charlie McCarthy, The Lone Ranger, etc.). Will pay up to \$600 depending on style and condition. *Doug Heinstead, 1439 Hillcrest Drive, Fridley, MN 55432; 612-571-1387.*

SAMS VCR facts, new or used but must be complete and clean. any quantity, any numbers. *Nancy Hauver, 34 Burlington Ave., Rochester, NY 14619.*

Service manual or schematic for Goldstar model TSR-581 AM/FM stereo cassette recorder. *Hank's Place, 1423 Jordan Drive S., Salem, OR 97302; 503-399-1423.*

Precision Apparatus tube checker chart (any year past 1957) for a model 640 chart, form TRC-G2G; power transformer for a B&K 700 tube checker. State price. *Alfred J. Hruska, Al's Radio and TV Service, 920 N. 17th St., Nederland, TX 77627; 409-722-9263.*

Suppliers of spare parts and repair handbooks (copies accepted) for IBM PC AT, COMPAQ 386 and H-P Scanjet. *Indico S.A., Ayacucho 1942, P.3, 1112 Buenos Aires, Argentina.*

Score model FC147 filament checker in good condition. *Paul Capito, 637 W. 21st St., Erie, PA 16502.*

Tentel TSH-V5, TQ600, tape tension gauge, mint condition, \$600. *David Ripple, 226 Adelpia, San Antonio, TX 78214; 512-924-1830.*

Score PR-57 ac power supply; Panasonic PV-6000 portable VCR or similar. *Ed Herbert, 410 N. Third, Minersville, PA 17954.*

For Knight KG 660 battery eliminator, a transformer (Basler BE 9948) and wiper arm and shaft. *Tom Pennington, 177 Carlisle Ave., S. Lehigh Acres, FL 33936; 813-369-8074.*

Schematic or photocopy for Yorx Radio, stereo model M-2400 (need directions for restringing dial cord). Will purchase or copy and return. *D.R. Walthall, 1308 St. Louis, Gonzales, TX 78629; 512-672-2794.*

Complete Sony TV, chassis SCC-548F-A for model KV-2675R; remote control needed for the same. Please quote price. *George Broadway, Nebraska TV & Stereo, 1209 Royal Drive, Papillion, NE 68046; 402-339-3894.*

Old Score equipment: SM112 "Service Master", RC-24 "Parts Pack", CG-25 "Little Huey", TR-110 "Transi-Master", TC-114 "Mighty Mite II", TR-115, TM-116, PR-111, ES102, PS103, H36, RS106, BE113,

ATTENTION TECHNICIANS

- ★ JOB OPENINGS
- ★ MONTHLY TECHNICAL TRAINING PROGRAM
- ★ BUSINESS MANAGEMENT TRAINING
- ★ SDC SATELLITE NEWS
- ★ CERTIFICATION
- ★ TECHNICAL SEMINARS

All of this in a nonprofit international association for technicians

FIND OUT MORE:



604 N. Jackson St.
Greencastle, IN 46135
1-800-359-6706

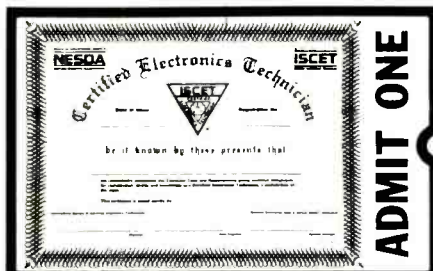

Your Ticket To SUCCESS

Over 25,000 technicians have gained admittance worldwide as certified professionals. Let your ticket start opening doors for you.

IS CET offers Journeyman certification in Consumer Electronics, Industrial, Medical, Communications, MATV, Radar, Computer, and Video. For more information, contact the International Society of Certified Electronics Technicians, 2708 West Berry St., Fort Worth, TX 76109 • (817) 921-9101.

Name _____
Address _____
City _____
State _____ Zip _____

Send material about IS CET and becoming certified.

Send one "Study Guide for the Associate Level CET Test." Enclosed is \$5 (+ \$1 postage).

LEARN VCR CLEANING/MAINTENANCE/REPAIR

EARN UP TO \$1000 A WEEK WORKING PART TIME FROM YOUR OWN HOME!



THE MONEYMAKING OPPORTUNITY OF THE 1990's

IF you are able to work with common small hand tools, and are familiar with basic electronics (i.e. able to use voltmeter, understand DC electronics)...

IF you possess average mechanical ability, and have a VCR on which to practice and learn...then we can teach YOU VCR maintenance and repair!

FACT: up to 90% of ALL VCR malfunctions are due to simple MECHANICAL or ELECTRO-MECHANICAL breakdowns!

FACT: over 77 million VCRs in use today nationwide! Average VCR needs service or repair every 12 to 18 months!

Viejo's 400 PAGE TRAINING MANUAL (over 500 photos and illustrations) and AWARD-WINNING VIDEO TRAINING TAPE reveals the SECRETS of VCR maintenance and repair - "real-world" information that is NOT available elsewhere!

Also includes all the info you'll need regarding the BUSINESS-SIDE of running a successful service operation!

FREE INFORMATION

CALL TOLL-FREE 1-800-537-0589
Or write to: Viejo Publications,
3540 Wilshire Bl., STE 310
Los Angeles, CA 90010, Dept. EST

Circle (24) on Reply Card

F53, DVM32, TFI662. Working or not, can pay some if working and complete manuals, etc. If unwanted donate to good cause. Will pay shipping COD. Send condition, price. *G. Griffin, 280 Milly Ave., Myrtle Creek, OR 97457.*

Working or repairable PC-D chassis for GE 25-inch console. State condition and price. *Larry P. Huckleba, Dixie TV Sales & Service, 6 Buchanan St., Newnan, GA 30263; 404-253-6566.*

Schematic and owner's manual for a model STV52 STV decoder manufactured by CATV division for Oak Industries. *Joe Varas, 449 Torry Ave., Bronx, NY 10473.*

NRI course for TVs and VCRs without kits. *Marcel Lotwin, Apartado Postal 11-456, Mexico 11 D.F. 06100, MEXICO.*

Operating manual for Accurate Instrument model 161 utility tester for testing tubes. Will buy or copy and return. *Carpender's Consumer Electronics, 33670 N. Forrest Drive, Gages Lake, IL 60030; 312-223-9232.*

Knight KG-686 RF generator; 83YX137 AF generator. *C.T. Huth, 229 Melmore St., Tiffin, OH 44883; 419-448-0007.*

Instructional manual for operating an RCA model WO 535A oscilloscope. Will pay or copy and return. *John Bullister, RD#4 Blackburn Road, Sewickley Hts., PA 15143; 412-741-1447.*

Schematics for Supre-Macy TV 19 TDM: Power Pac 587-000-91 power supply; Dynaco A-431 transformer. *Fred Washington, 4004 Prospect Ave., Kansas City, MO 64130.*

Operator's manual for RCA model WO-33A oscilloscope. Will buy or copy and return. *Anthony Carelli, 8039 42nd Ave., Kenosha, WI 53142; 414-694-7940.*

Rider service manuals, volumes 1-5 (not abridged editions), 20, 23, 24, 25, 26, and TV manuals 1 and 2. Please send price and condition. *McPherson Electronics, 107 S. Hennepin Ave., Dixon, IL 61021.*

Variable voltage isolation transformer high voltage probe. *David Bruce, 517 E. Atchison, Jefferson City, MO 65101; 314-635-8931.*

Sencore CA-55 capacitor analyzer; Heath ID-5252 audio load. *Michael D. Lewis, 6070 Lincoln Road, Oregon, WI 53575.*

Schematic, service manual and/or photocopy for Sansui G9700 stereo receiver, 200W/channel, manufactured 1978 to 1980. *K.U.M.C. Telecommunications, attn. D.C. Sweeney, 39th and Rainbow, Kansas City, KS 66103.*

Operation manual and schematic for B&K Precision Dynascan model 600 tube checker. *Larry Cook, 362 E. South, Richland Center, WI 53581; 608-647-4678.*

Schematic and/or service manual for Remington Rand 1259S desktop calculator. *T. Croce, 130 Woodbine Drive, East Hampton, NY 11937.*

Sams's photofacts #1832 through #2598. Will pay

reasonable price. Prefer response from Florida. *Jennings Hanson, 735 Clematis Road, Venice, FL 34293; 813-493-4159 or 813-497-0108.*

Service manuals for JVC 4VR5446 receiver, ACOUSTECH X double power amplifier. \$20 for original, \$10 copy of each. *Ursi Lewczuk, 1615 W. Montrose Ave., Chicago, IL 60613; 312-528-1728.*

NRI computer microprocessor master course in servicing, any 1985-1988 edition, with or without the Sanyo or Packard Bell computer. Very reasonable. *Joseph Wegner, Jr., P.O. Box 262, Glendale, CA 91209.*

Servicing information for Symphonic VCR model 6000, Heath/Zenith TV model GR-2700, Casio keyboard model CZ101, AM/FM stereo model SA-X35; source for IC Motorola MC 724P or HEP 570 quad 2-input RTL NOR gate. *William P. Jarvis, 1214 Fifth Ave., Beaver Falls, PA 15010.*

Schematic and service information for Mitsuba model 3700S TV, by Samsun. Copy will be fine. *B.L. Blackmore, 50155 Calcutta-Smiths Ferry Road, E. Liverpool, OH 43920; 216-385-0849.*

FOR SALE

Sams ARs, volumes 19-22, 24-28, 30-33, 35, 36, 38, 39, 42, 43, 46, 47, 49-52, 54, 58-70, 73-81, 84-100, 102-145, 157, 175, \$3 each plus fourth class postage; fused 0-1A AC meter in case, \$12.50 ppd. *Jim Furago, Box 6313, Minneapolis, MN 55406.*

Sencore VA62 video analyzer, VC63, NT64 accessories, with manuals and cables, \$2,000. *Ken Kuster, 106 Pow Wow Road, E. Kingston, NH 03827; 603-642-5463 (evenings).*

New Diehl Mark III, \$55, used \$25; Mark V needing repair, \$50; new Mark V, \$175; Mark IV for parts, \$35 — add \$5 shipping to each order; Diehl literature, issues 1, 3 and 7, \$3 each plus \$.50 for shipping and handling. Money order only. *Kenneth, 2107 Sixth Ave., Canyon, TX 79015; 806-655-9554 (noon til 3 p.m.).*

Sams Photofacts #1200 and earlier, \$.50 each plus postage, quantity discounts: Sams manuals, CB series, AR series and TSM series, \$2.50 each plus postage (send list); RCA TV modules, half-off servicers list, for chassis CTC46 to CTC92 (send list). *Vincent E. Price, 122 Lafayette Ave., Buffalo, NY 14213; 716-735-3671 after 5 p.m. EST, 716-278-2161 9 a.m. to 4 p.m. EST.*

Fairchild model 766H/F oscilloscope, solid-state, main frame, dc-100MHz vertical response, 79-02A plug-in dual trace, 10mV/cm sensitivity with instruction manuals, schematics, alignment, parts list, works like new, \$1,075. *Frank Czirok, 16 Clay Road, Carlisle, PA 17013; 717-249-9600.*

OK Tools model 1010 2-pound portable 10MHz oscilloscope with rechargeable batteries and adapter, \$200; Sencore DVM-37, \$200. *Alan Weinberg, 1742 Avenida Sirio, Tucson, AZ 85710; 602-750-0393.*

OWNERS RETIRING — 4-bench auto electronics servicenter and 2-bench TV/video servicenter with complete inventory of parts, manuals and equipment. Send SASE for list and prices. *Community Radio & TV, 9445 Indianapolis Blvd., Highland, IN 46322; 219-924-4400.*

Sencore SG-165 stereo analyzer, \$375; EICO model 460 scope, \$50; Sencore PS-43 battery power supply, \$20; color test jig #10J106, four adaptors and new CRT, \$125. All in excellent condition. *George Broadway, Nebraska TV & Stereo, 1209 Royal Drive, Papillion, NE 68046; 402-339-3894.*

Voltmeter. Sencore FEI60 and B&K 177, both for \$50; Sams Quickfacts, four volumes, \$15 each; B&K 1246 pattern generator, \$180; B&K 466 picture tube tester/rejuvenator, \$150; Sams Photofacts, 44 sets, #485 to #1553 and #2227, \$1.50 each or \$55 for all. Add shipping. *Sal Cribari, 1312 Well Drive, Camp Hill, PA 17011; 717-763-1855.*

Sencore test equipment: SC61 scope and PR57 ac power supply, in factory sealed boxes, like new, out of warranty, both for \$2,200. *Dave, Future Video Services, 3490 N.W. 37th St., Lauderdale Lakes, FL 33309; 305-486-3175.*

Sencore test equipment, like new: VA-62 video analyzer, VC-63 VCR test accessory, NT-64 pattern generator, EX231 expander, \$2,600; SC-61 waveform analyzer, \$2,000; 1655 B&K ac power supply, \$475; Leader LOG688 portable color pattern generator with acc., \$350; HP 6206B dc power supply, \$300; HP 120B single-trace scope, \$200. *Thomas Solak, 2507 N. Major, Chicago, IL 60639; 312-745-9595.*

Modules for T989, T995, T991, T815, T809 Magnavox; Tubes, new in box; schematics — Magnavox paper and fish, Fischer paper and fish; miscellaneous parts. Write for complete list. *Bill Curry, 422 N. Fifth, Marshall, MN 56258; 507-532-6473.*

Magnavox factory service data, 1966-1984, most new or like new with notes added, \$600; RCA factory service data, 1972-1982, plus Technical Reference Library, new condition, \$300; Zenith factory service data, 1972-1980, plus book of 1961-1975 schematics only, new condition, \$300. Send cashier's checks. Will ship UPS COD. *George W. Crouch, ACE TV & Electronics, 4018 Lillian Drive, Concord, CA 94521.*

New B&K 467 rejuvenator, in box, with 11 sockets, never used, \$450; yoke flyback tester with high-voltage probe, never used; Beckman Tech 300 digital multimeter, 100s stk chips and transistor. *A.A. Salim, 2088 Anthony Ave., Bronx, NY 10453; 212-364-3917 or 212-295-8296.*

Measurements model 803A FM generator, \$200; Sinadder 3, like new, with book, \$250; Sencore SG165 stereo generator, \$300. All negotiable. *Joseph Silver, 1883 E. Main St., Rochester, NY 14609; 716-288-1520 days, 716-654-8370 evenings.*

Sencore VA62 video analyzer with 50k HV probe; AC Powerite model PR57 variable isolation transformer; model VC63 VCR test accessory; model NT64 NTSC pattern generator; Bell & Howell XL-20 microfiche reader. All like new. All accessories included with wired RCA stand. Best offer. *Raymond Strozier, 433 Wallace Gray Rd., Newnan, GA 30263; 404-253-2696.*

Out of business! Service manuals (Sams, Quasar, NAP, Sharp, Coronado); test equipment; tubes; parts inventory; 41-inch TV; office equipment; shelves; display platforms; 1978 Dodge Tradesman

van; modules; B&K 467 scope; cash register; check writer; file cabinets; NAP/Sylvania parts kits; some satellite electronics; building adaptable to many uses, great hunting and fishing area. Send SASE. R.N. Yasko, Fremont TV, 407 E. Main St., Fremont, WI 54940; 414-448-2239.

RCA outside double-face neon sign, 4'x6' with raised lettering; Zenith outside double-face neon sign 4'x6', no business name on either sign. Moscow Radio & TV, Max E. Bingman, Box 9088, Moscow, ID 83843; 208-882-2273.

Sony service manuals, microfiches of products made mostly in 1986, set of 200 s/m, \$800, set of 180 s/m, \$720. Send SASE for list. 20th Century TV & Stereo, 1615 W. Montrose Ave., Chicago, IL 60613; 312-528-1728.

Owner retiring! TV test equipment, send SASE for list; N.O.S. tubes, send a list of what you need and SASE for price quote. Maurer TV Sales & Service; 29 S. Fourth St., Lebanon, PA 17042; 717-272-2481.

HP model 410B VTVM, \$95; HP model 130C scope, \$195; Tektronix model RM504 scope, \$165. Add \$10 for insured UPS shipping. COD is OK. Fred Jones, 407 Morningbird Ct., Niceville, FL 32578; 904-678-1803.

Tektronix 2236 scope w/extras, \$1,750; Pace MP-1 desoldering station w/extras, \$275; 10 Diehl

Analysts (five new MK Vs, one Mk V Demo., four new Mk IIIs) all 10 for \$400. Jim Taylor, Heidi-Tek, 10943 Deep Creek Road, Apple Valley, CA 92308; 619-247-7055 or 619-247-7996.

Sams Photofacts #1100 to #2599; small amount of parts and equipment. Jack Stewart, 3444 Charlemagne Drive, Decatur, GA 30034; 404-987-2522.

New RCA receiving tubes, 75% discount from list. Send SASE for list. James Vandemark, Box 3472, Santa Rosa, CA 95402.

Sams schematics library to #2606 and hundreds of factory manuals, \$2,650 or best offer; B&K 11472C scope, \$350; 520 transistor checker, \$150; Sencore VA-48, \$445; TF-46 transistor checker, \$225; an "as is" LC-53, \$95; Beltron CRT tester with adapters, \$295; 40 VCR service manuals, \$250. Write for other items. Micky Clark, 5615 Deer Creek Dr., Ferndale, WA 98248.

Sams photofact sets #69-#496, all 264 sets \$100 or best offer; Sencore model SSI37 sweep circuit analyzer with manuals, needs test leads, \$45; Eico model 950B resistance-capacitance comparator bridge tester with manual, needs repair, \$35. Add shipping. John Brouzakis, 247 Valley Circle, Charleroi, PA 15022; 412-483-3072.

Two Big Mack Sencore CRT rejevinators with many adaptors, needs minor repairs; B&K 1076

TV analyst, complete, as is; HP 712B power supply, works well, heavy duty. No reasonable offer refused. COD cash only. David Lehmann, RR2 Box 104, Mansfield, MO 65704; 417-924-3350.

Sencore SGI65, \$750; Sencore CR70, \$650. Like new. Alan R. Mahnken, P.O. Box 2792, N. Attleboro, MA 02763; 617-762-5690, ext. 245 (days), 508-695-4492 (evenings).

Out of business! Miscellaneous Sams photofacts #1000 to #1699, test equipment, office equipment, parts inventory, merchandise inventory, Radio Shack model 4 computer, DMP-400 printer & software, building and property. Send SASE for list. David A. Day, Flori-Day Electronics, 44 Ave. E, Apalachicola, FL 32320; 904-653-9637.

Sencore SC-61 scope, one year old, 100MHz digital dual trace, one probe readout DC watts, peak to peak, frequency and delta measurements, eliminates graticule counting, \$1,500 sacrifice, \$3,000 new. VideoSync, 2208 N. Illinois St., Swansea, IL 62221; call collect 618-235-4735.

Sencore VA-62, NT-64, VC-63, like new, \$2,500. Bell Music, Greg Sabin, 533 W. Market St., Akron, OH 44303; 216-253-9171.

Large quantity of tubes and Sams; some modules and other miscellaneous equipment. SASE for list. Boyle Electronics, 541 S. Fourth St., Danville, KY 40422; 606-238-7935.

Classified

Advertising rates in the Classified Section are \$1.65 per word, per insertion, and must be accompanied by payment to insure publication.

Each initial or abbreviation counts as a full word.

Minimum classified charge \$35.00.

For ads on which replies are sent to us for forwarding (blind ads), there is an additional charge of \$40.00 per insertion to cover department number, processing of replies, and mailing costs.

Classified columns are not open to advertising of any products regularly produced by manufacturers unless used and no longer owned by the manufacturer or distributor.

FOR SALE

TV/VCR TUFF TIPS listed by mfg. & model. Over 400 tips. \$21.95. TV Tips only \$11.95, VCR Tips only \$13.95. **VCR CROSS-REFERENCE** listing for electronically similar manufacturers, RCA, GE, Sylvania, Panasonic, Quasar, Magnavox, Philco, & J.C. Penney, \$19.95. **TV/VCR FAILURE HISTORIES.** Multiple cures for most problem areas. Send \$7.95 with mfg. and model number. Money will be refunded with free sample if model is not on database. Add \$1.50 postage and handling. TECH CURES, 4825 Fredericksburg Road, San Antonio, Texas 78229. 12-88-TFN

VHS-VCR Repair Solutions Volumes I, II, III, IV. Each contains 150 symptoms and cures, cross reference chart, free assistance. Each \$11.95, any two \$19.95, any three \$29.95, all \$39.95. Eagle Electronics, 52053 Locks Lane, Granger, IN 46530. 01-89-TFN

TEST EQUIPMENT. Sencore SC-61 \$2,000, Sencore LC-53 \$450, Simpson 150 Clamp-On Ampmeter \$25, Amprobe RS-3 Clamp-On Ampmeter \$40, Sony MBC-555 Computer MS-DOS compatible with software \$200. Manuals and test leads included with all units. Paul Rawlings, 4010 Westminster, Midland, TX 79707, 915-697-7132. 8-89-1T

PHOTOFACTS: Folders under #1400, \$4.00. Above #1400, \$6.00. Sent same day first-class postpaid. Loeb, 414 Chestnut Lane, East Meadow, NY 11554. 6-89-3T

REDUCED 75%. Diehl Mark V scanner \$249, Diehl Mark III scanner \$99. New. 2805 University Ave., Madison, Wis. 53705, 608-238-4629, 608-233-9741. 3-89-tfn

TV TOUGH DOGS: 300 symptoms and cures. Send \$8.95 to DAVIS TV, 11772 Old Fashion Way, Garden Grove, CA 92640. 10-87-1fn

TV TROUBLESHOOTING: Over 300 problems/solutions. Nothing old listed. \$12.00, add \$1.50 shipping. Refund if not satisfied. Jones Enterprises, Box 702, Niceville, FL 32578. 6-89-1fn

ELECTRONIC COMPONENTS: Free 192 page catalog including capacitors, resistors, relays, connectors, soldering equipment and supplies. MOUSER ELECTRONICS, 1-800-992-9943. 8-89-1T

ELECTRONIC PARTS ORDERING INFORMATION. Complete how-to-list for over 150 major manufacturers. Send \$14.95 plus \$2.50 S/H to JS Enterprise, P.O. Box 62, Penland, VA 22846. 8-89-1T

TV/VCR REPAIR TIPS VOLUMES I AND II. Each with 1,000 up-to-date problems/cures listed by model and chassis for quick easy lookup. \$29.95 per volume. Add \$2.50 postage and handling. Computer Assistance, Box 232026, Anchorage, AK 99523. 8-89-3T

COMPUTER TV/VCR REPAIR TIPS DATABASE PROGRAM IBM Compatible (w/hard drive). Scan symptoms and cures by model and chassis. Add, change, delete, print out. Includes database with over 1,000 up-to-date repair tips. \$69.95 plus \$2.50 postage and handling. Computer Assistance, Box 232026, Anchorage, AK 99523. 8-89-3T

BUYING AND SELLING late model Electronic Test Equipment, Tektronix, HP, Fluke, Wavetek, etc. O'scopes, Signal Gen's, Pwr. Supplies, etc. Cal-Scope, 473-707 Macara Ave., Sunnyvale, CA 94086. (408) 730-4573. 8-89-3T

VINTAGE TV'S, Collectable radio quarterly! "Sight Sound Style" has articles, photos, ads, current values! \$14 yearly. SSS, Box 2224E, So. Hack., NJ 07606. 8-89-1T

INTEGRATED CIRCUITS—Lowest prices on Admiral, GE, NAP, Philco, RCA, Sears, Sylvania and Zenith types. Write PEC, Box 894, Union, N.J. 07083. 8-89-4T

SERVICES

SPEAKER REPAIR. 4"-18" Speakers reconed. Cross-over parts. Orban Audio, 119 7th St. NW, North Canton, Ohio 44720, (216) 497-9932 6pm-9pm EST. 4-89-tfn

BUSINESS OPPORTUNITIES

ELECTRONICS BUSINESS: very diverse, factory sys contracts, installations for major dealers, growing security dept., all equipment & truck included, \$55,000. Northern N.J. 201-575-6217. 6-89-3T

TV SALES & SERVICE: Beautiful Northern Arizona. Retiring due to health. Loaded with up to date test equip. Huge inventory, Sams photofacts from year one. Also Sharp, Fisher, JVC, Sansui, Sanyo, Samsung, RCA, GE, etc. Same location 26 years. Priced to sell, \$45,000. For more information 602/635-4352. 7-8-2T

LARGE AUDIO/VIDEO SERVICE BUSINESS. In sunny S.W. city. Established 20 yrs. Well-equipped. Price & terms negotiable. (602) 298-8827. eves. 8-89-tfn

VCR SERVICE COMPANY in beautiful Monterey, CA. \$40,000-\$50,000 yearly sales. \$25,000 in parts, equipment, furniture and fixtures. Using only 400 square feet of 2,200 square feet. Busy drive-by corner building. Lease/rent—Only \$675/mo. for entire facility. Lots of room to expand at no extra rent cost. Illness forces give away sale price of only \$39,500. Hurry! Won't last. 408-649-6036. 7-89-3T

AUDIO SALES/SERVICE: Fully operational, profitable stereo business seeks new owner. Location: Fast-growing Research Triangle, NC. Great place to live. Tom 919-286-3891. 8-89-2T

ROCHESTER, NEW YORK, ESTABLISHED 1955, owner retiring, will train, 2 way, auto sound, telephones, sales, service; building, 2 bays. (716) 654-8370. 8-89-1T

WHY PAY SENCORE S1295?

TEST/CLEAN/RESTORE with a UNIVERSAL CRT ADAPTER that fits all CRT testers and quickly hooks-up to all CRT's on the market (now or in the future). Guarantees profit & total CRT servicing. Used by TV Repair, US Govt., Airlines, Computer Serv., Dept. of Defense. Patented Adaptor-Sockets-CRT Reference/Setup book—Only \$59.95 plus \$2.50 postage & handling. Our 6th year. Over 15,000 sold. Chargecards/Checks/COD. Money Back Guarantee.

FREE CALL 1-800-331-9658
DANDY MFG. CO./RANDALL ELECTRONICS
 (918) 682-4286, 2323 Gibson St., Muskogee, OK 74403

Circle (25) on Reply Card

WE'RE THE ONE . . .

- With over 12,000 Electronic Products
- With LOW Prices & Volume Discounts
- With the PRB LINE of Replacement Belts & Tires

Call Toll FREE

1-800-558-9572 in Wis. 1-800-242-9553
 24 HOUR ORDERING: FAX: 414-473-4727

"First in Quality And Service"



P.O. Box 28 • Whitewater, Wisconsin 53190

Circle (26) on Reply Card

Tech's Guide To Pricing
 updated new 5th edition... a framework for setting rates that apply to Hi-Tech products... a formula that guarantees SUCCESS!
 Call Toll Free for details **1-800-228-4338** 8/5 CST

Circle (27) on Reply Card

FIX VCR's

3 out of 4 VCR breakdowns are due to mechanical problems.

Do you have the tools to find these problems?



TENDEL® Does!
 Call Toll Free
(800)538-6894
 In Calif. (916) 939-4005



Circle (28) on Reply Card

REPRINTS

Interested in ordering article reprints out of this or another issue? * Reprints can be excellent learning tools for your technical staff and great marketing tools for your sales staff. Call or write Kelly Hawthorne at Intertec Publishing Corp., P.O. Box 12901, Overland Park, KS 66212; (913) 888-4664.

* Minimum order 500 copies.

Ad Index/Hotline

Company	Page Number	Reader Service Number	Advertiser Hotline
C.G. Instruments	19	35	513/434-6952
Cleveland Institute of Electronics	1,1A-B	3	800/321-2155
Dandy Mfg. Co.	60	25	800/331-9658
ETA	57		
Fluke, John Mfg. Co., Inc.	5	6	800/227-3800
Heath Co.	53		800/444-3284
Iscet	57		
Joseph Electronics	38	12	800/323-5925
Leader Instrument Corp.	3	4,5	800/645-5104
M.A.T. Electronics	39	13	800/628-1118
Matsushita Services Co. (Parts Div.)	40-41	14	201/348-7589
Matsushita Services Co. (Publications Div.)	17	9	201/392-4281
MCM Electronics	44	15	800/543-4330
Nesda	55		
NTE Electronics, Inc.	51	22	800/631-1250
Nutronix, Inc.	55	10	313/939-4710
Paladin Corporation	7	29	805/499-0318
Parts Express Int'l., Inc.	45	16	513/222-0173
Philips ECG	47	17-20	800/225-8326
Portasol, Inc.	IBC	2	704/543-6239
Prime Electronics	60	26	414/473-4727
PTS Corp.	49	21	800/333-PTS1
Sencore, Inc.	IFC	1	800/843-3338
Sony Service Company	23		201/930-6392
Sperry Tech, Inc.	60	27	800/228-4338
Tentel	60	28	800/538-6894
U.S. Instrument Rentals	15	30	800/824-2873
Viejo Publications	57	24	800/537-0589
Windsor Technologies, Inc.	11	8	415/456-2209
Zenith	BAC		
3M Magnetic Media Group	9		

ADVERTISING SALES OFFICES



KANSAS CITY, MISSOURI
 Greg Garrison, Sales Manager
 P.O. Box 12901
 Overland Park, KS 66212
 Phone: (913) 888-4664
 Fax: (913) 541-6697
 Telex: 42-4156 INTERTEC OLPK

OXFORD, ENGLAND
 Nicholas McGeachin
 Roseleigh House, New Street
 Deddington, Oxford OX5 4SP
 Phone: (0869) 38794
 Telefax: (0869) 38040
 Telex: 837469 BES G

TOKYO, JAPAN
 Mashy Yoshikawa
 Orient Echo, Inc.
 1101 Grand Maison
 Shimomiyabi-Cho, 2-18
 Shinjuku-ku, Tokyo 162, Japan
 Tel: 03-235-5961
 Telex: J-33376 MYORIENT

FREWVILLE, SOUTH AUSTRALIA
 John Williamson
 Hastwell, Williamson, Rep. Pty. Ltd.
 109 Conyngham Street
 Frewville 5063
 South Australia
 Phone: (08) 79 9522
 Fax: 08 79 9735
 Telex: AA87113 HANDM



850° F. Zero Volts.

Introducing The Hot, New Cordless Soldering Tool You Can Take Anywhere.

No Cords. No Batteries. No Cartridges.

No matter where your job takes you, you can take Portasol®: The cordless, refillable butane gas-powered soldering tool.

And Portasol eliminates all risk of leakage current, making it ideal for soldering or desoldering sensitive circuits.



Soldering



Desoldering

Four Tools In One.

Within seconds, Portasol converts into a blow torch, hot blower, or hot knife. Plus, the tool carries a full two year warranty.**

Portasol has the power you need. Especially when you haven't got the volts. See for yourself.

Contact us today for the name of the distributor nearest you.



Blow Torch

Only 7 inches long and weighing less than 3 ounces, this micro-precision, anti-static* soldering tool is ergonomically designed

and provides up to 90 minutes of continuous use. It refills in seconds with ordinary butane lighter fuel. The adjustable temperature control regulates the equivalent of 10-60 watts of power, heating a soldering tip to 850°F. Safely.

portasol®
INC.

A Subsidiary of Oglesby and Butler Group plc

7422 Carmel Executive Park, Charlotte, NC 28226
704-543-6239, FAX 704-543-6839

Circle (2) on Reply Card

* Surface conductivity is approximately 10¹² Ω / □ .
** Excludes tips and accessories.

PLAY IT SMART!



**INSIST ON
GENUINE ZENITH
FACTORY-FRESH
REPLACEMENT PARTS
NOW AVAILABLE AT
AUTHORIZED
EXCHANGE COUNTERS
THROUGHOUT THE U.S.**

Two of the most important reasons for exchanging Zenith replacement parts through your participating distributor's Exchange Program:

- 1) Your replacement part will most likely contain the latest Zenith engineering updates,
- 2) You will be assured of receiving a factory-fresh replacement part remanufactured and serviced for reliability by Zenith people

as knowledgeable and dedicated as those who made the original.

Don't risk exchanging sophisticated Zenith modules, tuners, channel selectors and sub-assemblies anywhere else.

Write today and we'll help you locate an authorized distributor Exchange Counter near you!

ZENITH
The quality goes in before the name goes on.®

Zenith Service, Parts & Accessories/11000 Seymour Avenue/Franklin Park, IL 60131 • A Division of Zenith Electronics Corporation

Find The Defective Capacitors, Coils, Resistors, SCRs And Triacs That All Other Testers Miss ...

Presenting a new, improved, dynamic and mistake proof LC Analyzer that finds defective components all other testers miss.

- Dynamically tests capacitors for value from 1 pF to 20F, leakage with up to 1000 volts applied, dielectric absorption and equivalent series resistance (ESR).

- Dynamically tests inductors, in-or-out of circuit, from 1 uH to 20 Henrys for opens, shorts, value, and detects even one shorted turn.

- Dynamically tests SCRs, Triacs, High Value Resistors, and locates the distance to within feet of an open or short in a transmission line for an added bonus.

- Automatically makes all of the tests, compares them to EIA (Electronic Industries Association) standards and reads the results as Good or Bad. Enter all information right from the component without look-up charts, calculations, or errors.

- Extends your testing capability to places where an AC cord won't reach, with rechargeable 9 hour battery or AC operations.

- An added feature alerts you that the fuse has opened, and that there may be residual high voltage on the component under test.

New!
And Improved!



It's like having your own Standards Engineer with you at all times.

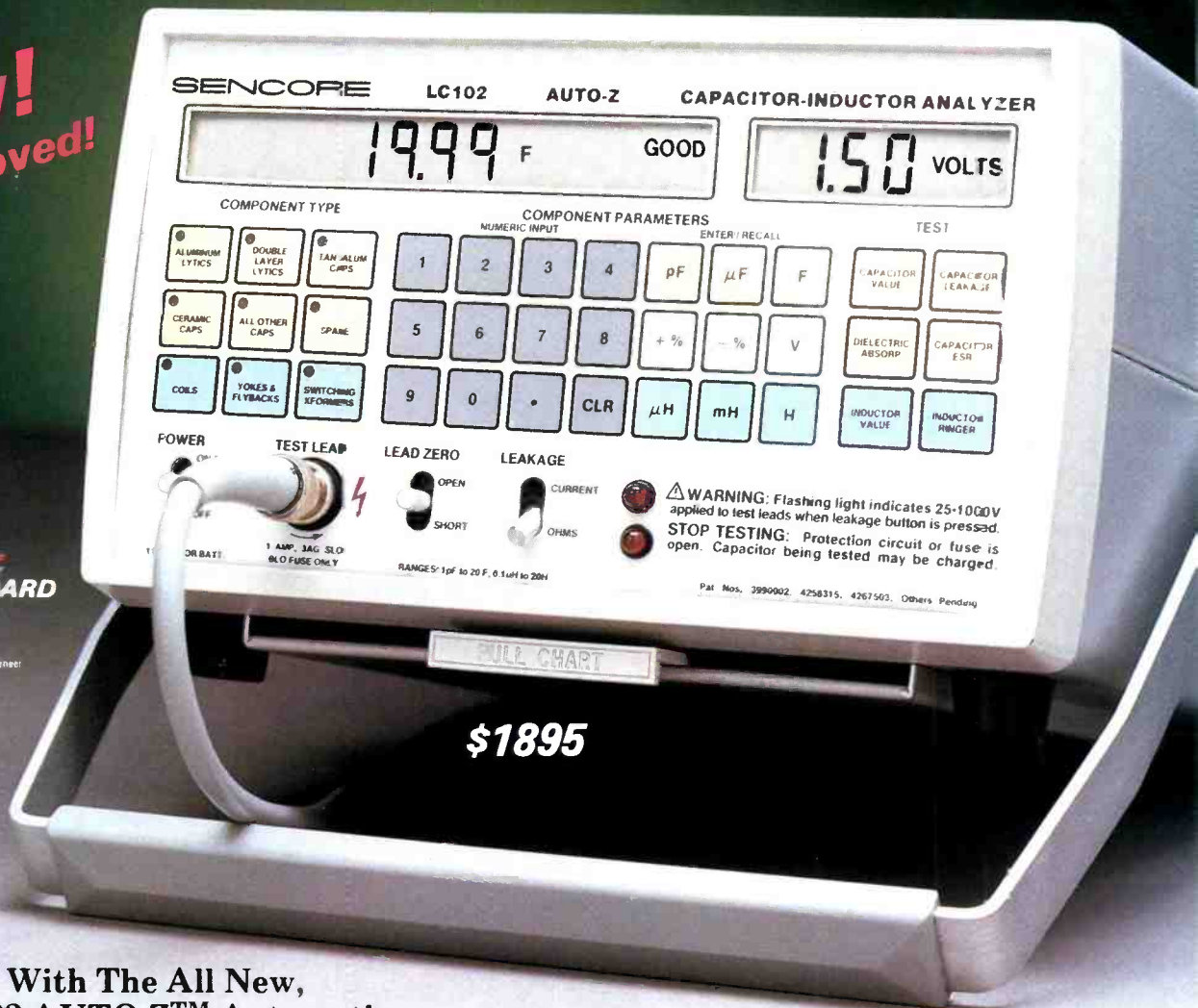

\$1895

With The All New,
LC102 AUTO-Z™ Automatic
Capacitor-Inductor Analyzer.
Four Patents

Call 1-800-SENCORE
In Canada Call 1-800-851-8866

Circle (1) on Reply Card

THE MAGAZINE FOR CONSUMER ELECTRONICS SERVICING PROFESSIONALS

ELECTRONic™

Servicing & Technology

JULY 1989/\$2.50

Servicing Zenith Microcomputers • Scan-Rectified Voltage Sources
Implementing an Electrostatic Discharge Awareness Program

Setting up an electronics servicing workbench

